

রেজিস্টার্ড নং ডি এ-১

বাংলাদেশ



গেজেট

অতিরিক্ত সংখ্যা
কর্তৃপক্ষ কর্তৃক প্রকাশিত

মঙ্গলবার, জুলাই ১৬, ২০২৪

[বেসরকারি ব্যক্তি এবং কর্পোরেশন কর্তৃক অর্থের বিনিময়ে জারীকৃত প্রজ্ঞাপন]

**Civil Aviation Authority of Bangladesh
Gazette**

Dhaka, ১২ বৈশাখ, ১৪৩১/25 April, 2024

FOREWORD

1. No, CAAB 30.31.0000.111.37.007.19/23 – In exercise of the power conferred by Section 47, read with Section 14 of the Civil Aviation Act, 2017 (Act No. 18 of 2017), hereinafter referred as the “Act”, the Chairman of the Civil Aviation Authority of Bangladesh is pleased to issue this Air Navigation Order (ANO) “ANO 6-2 on Operation of Aircraft- International General Aviation- Aeroplanes”.
2. This ANO 6-2 shall come into force with immediate effect.

Air Vice Marshal M Mafidur Rahman
BBP, BSP, BUP, ndu, afwc, psc
Chairman
Civil Aviation Authority of Bangladesh

(২২২২৩)
মূল্য : টাকা ১২০.০০

CHAPTER 0. GENERAL

0.1 Short Title and Commencement

This Air Navigation Order (ANO) will be called “ANO 6-2 on Operation of Aircraft, International General Aviation-Aeroplanes”, issued in accordance with Annex 6 on Operation of Aircraft Part II- International General Aviation-Aeroplanes to the Convention on International Civil Aviation and referred to herein as the “ANO 6-2” Issue No. 1. This ANO 6-2 shall be effective immediately upon publication in this Official Gazette.

0.2 Status of previous ANOs and applicability of this ANO.

- a) This ANO 6-2 will be applicable to the applicable stakeholders on the date of publication of the gazette.
- b) This ANO 6-2 supersedes all the previous ANOs on the Operation of Aircraft, International General Aviation-Aeroplanes
- c) Any order, instruction, directives, procedures, guidance material related to Operation of Aircraft, International General Aviation-Aeroplanes to be issued by the CAAB shall be treated as an integral part of this ANO 6-2.

0.3 ADMINISTRATIVE PROVISIONS

- 0.3.1 A service provider or operator who fails to comply with this ANO, may have his or her licence, certificate or authorization suspended or revoked, in addition to any other administrative sanction as prescribed under the Civil Aviation Act 2017.
- 0.3.2 An acceptance, approval, authorization or certificate issued or granted by the Authority before the commencement of this ANO shall be deemed to be valid and shall remain operational until it is revoked, annulled, replaced or it expires.

0.4 Explanation

The whole documents are stated about the Provisions include Standards and Recommended Practices on Operation of Aircraft of International General Aviation in accordance with ICAO Annex 6, Operation of aircraft, Part II- International General Aviation.

Standards are denoted by “Shall” which are treated as mandatory requirement. Applicable stakeholders are required to comply with those standards. The Chairman, CAAB, will take appropriate enforcement action when those requirements are not complied with.

Recommended Practices are denoted by “should” which are optional for the Stakeholders to comply, but they will endeavor to comply. Recommended Practices are stated in italic format.

Definitions of Standard and Recommended Practices stated in this document are given below: Standard: Any specification for physical characteristics, configuration, matériel, performance, personnel or procedure, the uniform application of which is recognized as necessary for the safety or regularity of international air navigation and to which applicable agencies or service provider or operator will conform in accordance with the provision;

Recommended Practices: Any specification for physical characteristics, configuration, matériel, performance, personnel or procedure, the uniform application of which is recognized as desirable in the interest of safety, regularity or efficiency of international air navigation, and to which applicable agencies or service provider or operator will endeavor to conform in accordance with the provision.

0.5 Status of ANO components

This ANO 6-2 is made up of the following component parts, they have the status indicated.

1.— *Material comprising the ANO proper*

- a) Provisions include Standards and Recommended Practices adopted from ICAO Annex 6 Part II and Industry best practices. They are defined in sub-section 0.4 above.
- b) Appendices comprising material grouped separately for convenience but forming part of the provisions.
- c) Definitions of terms used in the Standards and Recommended Practices which are not self-explanatory in that they do not have accepted dictionary meanings. A definition does not have an independent status but is an essential part of each Provision in which the term is used since a change in the meaning of the term would affect the specification.
- d) Tables and Figures which add to or illustrate a Provision and which are referred to therein, form part of the associated Provisions and have the same status.
- e) *Notes* included in the text, where appropriate, to give factual information or references bearing on the Standards or Recommended Practices in question but not constituting part of the Standards or Recommended Practices. Notes are stated in this ANO in italic font;

- f)) *Attachments* comprising material supplementary to the Standards and Recommended Practices or included as a guide to their application.

It is to be noted that some Standards in this ANO incorporate, by reference, other specifications having the status of Recommended Practices. In such cases, the text of the Recommended Practice becomes part of the Standard.

0.6 Control of the ANO and review process

- (i) This Document is the property of Civil Aviation Authority of Bangladesh.
- (ii) This ANO is under the full authority of the Chairman, Civil Aviation Authority of Bangladesh. Member Flight Standard & Regulations of CAAB is the custodian of the ANO 6-2.
- (iii) Member Flight Standard & Regulations is responsible for revision, distribution, retention and approval of the ANO 6-2.
- (iv) This ANO will be reviewed once a year considering ICAO Annex 6 Part II, other ICAO Annexes and their amendments and regulations of other regulatory authority.
- (v) Responsible Inspector(s) of FSR Division of CAAB having revision responsibility of this ANO performs schedule reviews at least once a year. If the review process does not lead to any change to the document, ANO is not updated/amended; but the review record is preserved.
- (vi) Other than the scheduled review, the document will be reviewed:
 - after changes of Act, Law etc relating to aviation;
 - after changes in regulations relating to aviation;
 - after changes of ICAO Annex 6 Part II;
 - after changes of other Annexes which dictate to change ANO 6-2;
 - after changes of regulations of other authorities such as FAA, EAA etc which will require to change ANO 6-2;
 - after changes in any documents of CAAB which will call for revising this document;
 - if service providers/operators or the users of the document ask for reasonable and objective changes;
 - if there are any mistakes/errors in the document and perform reviews as and when it deems necessary;

- (vii) After reviewing, if it becomes necessary to review the exiting provision or any portion of a provision of this ANO, it will be reflected through issuance of revision.
- (viii) If the revision requires more than 50% pages to be updated/ changed, it is recommended that a complete issue of the document be published, with new issue number and issue date, with issue number incremented by 1 (one) with the previous issue number.
- (ix) To identify revised content, the published revision of this document contains “R” symbol on the left margins indicating that the adjacent information on the page has been changed or revised. A new issue of a document does not contain change symbols. In the cases of revisions or new issue, a 'Revision Highlights' should accompany the documents indicating and briefing each significant change.
- (x) After approval and gazette notification, ANO will be published in CAAB website for the use of the stakeholders.

0.7 Dispute Resolution

- (a) Should there is any confusion of understanding of the content(s) of this ANO the matter should be brought to the attention of the Member Flight Standard & Regulations of CAAB for clarification.
- (b) In the circumstances, when any dispute or contradiction arises which cannot be resolved with the provisions of the ANO, the final decision is under the discretions of Member Flight Standard & Regulations of CAAB. Member Flight Standard & Regulations of CAAB may produce the issue before the Chairman, CAAB, if feels necessary.

ABBREVIATIONS AND SYMBOLS (used in this ANO)**Abbreviations**

AC	Alternating current
ACAS	Airborne collision avoidance system
ADREP	Accident/incident reporting
ADRS	Aircraft data recording system
ADS	Automatic dependent surveillance
AFCS	Automatic flight control system
AIR	Airborne image recorder
AIRS	Airborne image recording system
AOC	Air operator certificate
APCH	Approach
APU	Auxiliary power unit
AR	Authorization required
ARINC	Aeronautical Radio, Incorporated
ASE	Altimetry system error
ATC	Air traffic control
ATM	Air traffic management
ATN	Aeronautical telecommunication network
ATS	Air traffic services
CARS	Cockpit audio recording system
CAT I	Category I
CAT II	Category II
CAT III	Category III
CFIT	Controlled flight into terrain
CG	Centre of gravity
cm	Centimetre
CPDLC	Controller-pilot data link communications
CVR	Cockpit voice recorder
CVS	Combined vision system
DA	Decision altitude
DA/H	Decision altitude/height
DC	Direct current

D-FIS	Data link-flight information services
DH	Decision height
DLR	Data link recorder
DLRS	Data link recording system
DME	Distance measuring equipment
DSTRK	Desired track
EFB	Electronic flight bag
EFIS	Electronic flight instrument system
EGT	Exhaust gas temperature
EICAS	Engine indication and crew alerting system
ELT	Emergency locator transmitter
ELT(AD)	Automatic deployable
ELT ELT(AF)	Automatic fixed
ELT ELT(AP)	Automatic portable
ELT ELT(S)	Survival
ELT EPR	Engine pressure ratio
EUROCAE	European Organisation for Civil Aviation Equipment
EVS	Enhanced vision system
FANS	Future air navigation system
FDR	Flight data recorder
FL	Flight level
FM	Frequency modulation
ft	Foot
ft/min	Feet per minute
g	Normal acceleration
GBAS	Ground-based augmentation system
GCAS	Ground collision avoidance system
GLS	GBAS landing system
GNSS	Global navigation satellite system
GPS	Global positioning system
GPWS	Ground proximity warning system
hPa	Hectopascal
HUD	Head-up display

IAOPA	International Council of Aircraft Owner and Pilot Associations
IBAC	International Business Aviation Council
IFR	Instrument flight rules
ILS	Instrument landing system
IMC	Instrument meteorological conditions in
Hg	Inch of mercury
INS	Inertial navigation system
ISA	International standard atmosphere
kg	Kilogram
km	Kilometre
km/h	Kilometres per hour
kt	Knot
lbf	Pound-force
LED	Light emitting diode
m	Metre
mb	Millibar
m/s	Metres per second
MDA	Minimum descent altitude
MDA/H	Minimum descent altitude/height
MDH	Minimum descent height
MEL	Minimum equipment list.
MHz	Megahertz
MLS	Microwave landing system
MMEL	Master minimum equipment list
MNPS	Minimum navigation performance specification
MOPS	Minimum operational performance specification
NAV	Navigation
NM	Nautical mile
NVIS	Night vision imaging systems
N1	Low pressure compressor speed (two-stage compressor); fan speed (three- stage compressor)
N2	High pressure compressor speed (two-stage compressor); intermediate pressure compressor (three- stage compressor)
N3	High pressure compressor speed (three-stage compressor)
OCA	Obstacle clearance altitude
OCA/H	Obstacle clearance altitude/height

OCH	Obstacle clearance height
PANS	Procedures for Air Navigation Services
PBC	Performance-based communication
PBN	Performance-based navigation
PBS	Performance-based surveillance
RCP	Required communication performance
RNAV	Area navigation
RNP	Required navigation performance
RNPSOR	Required navigation performance and special operational requirements
RSP	Required surveillance performance
RTCA	Radio Technical Commission for Aeronautics
RVR	Runway visual range
RVSM	Reduced vertical separation minima
SBAS	Satellite-based augmentation system
SI	International System of Units
SOP	Standard operating procedure
SVS	Synthetic vision system
TAWS	Terrain awareness system
TCAS	Traffic alert and collision avoidance system
TLA	Thrust lever angle
TLS	Target level of safety
TVE	Total vertical error
UTC	Coordinated universal time
VD	Design diving speed
VS0	Stalling speed or the minimum steady flight speed in the landing configuration
VFR	Visual flight rules
VMC	Visual meteorological conditions
VOR	VHF omnidirectional radio range
VSM	Vertical separation minima
WXR	Weather radar
<i>Symbols</i>	
°C	Degrees Celsius
%	Per cent

ANO 6-2**SECTION 1, GENERAL****CHAPTER 1.1, DEFINITIONS**

When the following terms are used in the ANO for the operation of aeroplanes in international general aviation, they have the following meanings:

Acts of unlawful interference. These are acts or attempted acts such as to jeopardize the safety of civil aviation and air transport, i.e.:

- unlawful seizure of aircraft in flight,
- unlawful seizure of aircraft on the ground,
- hostage-taking on board an aircraft or on aerodromes,
- forcible intrusion on board an aircraft, at an airport or on the premises of an aeronautical facility,
- introduction on board an aircraft or at an airport of a weapon or hazardous device or material intended for criminal purposes,
- communication of false information as to jeopardize the safety of an aircraft in flight or on the ground, of passengers, crew, ground personnel or the general public, at an airport or on the premises of a civil aviation facility.

Advanced aircraft. An aircraft with equipment in addition to that required for a basic aircraft for a given take-off, approach or landing operation.

Aerial work. An aircraft operation in which an aircraft is used for specialized services such as agriculture, construction, photography, surveying, observation and patrol, search and rescue, aerial advertisement, etc.

Aerodrome. A defined area on land or water (including any buildings, installations and equipment) intended to be used either wholly or in part for the arrival, departure and surface movement of aircraft.

Aerodrome operating minima. The limits of usability of an aerodrome for:

- a) take-off, expressed in terms of runway visual range and/or visibility and, if necessary, cloud conditions;
- b) landing in 2D instrument approach operations, expressed in terms of visibility and/or runway visual range minimum descent altitude/height (MDA/H) and, if necessary, cloud conditions; and
- c) landing in 3D instrument approach operations, expressed in terms of visibility and/or runway visual range and decision altitude/height (DA/H) as appropriate to the type and/or category of the operation.

Aeroplane. A power-driven heavier-than-air aircraft, deriving its lift in flight chiefly from aerodynamic reactions on surfaces which remain fixed under given conditions of flight.

Agreement summary. When an aircraft is operating under an Article 83 *bis* agreement between the CAAB and another State, the agreement summary is a document transmitted with the Article 83 *bis* Agreement registered with the CAAB Council that identifies succinctly and clearly which functions and duties are transferred by the CAAB to that other State.

Note.— The other State in the above definition refers to the State of the principal location of a general aviation operator.

Aircraft. Any machine that can derive support in the atmosphere from the reactions of the air other than the reactions of the air against the earth's surface.

Air traffic service (ATS). A generic term meaning variously, flight information service, alerting service, air traffic advisory service, air traffic control service (area control service, approach control service or aerodrome control service).

Airworthy. The status of an aircraft, engine, propeller or part when it conforms to its approved design and is in a condition for safe operation.

Alternate aerodrome. An aerodrome to which an aircraft may proceed when it becomes either impossible or inadvisable to proceed to or to land at the aerodrome of intended landing where the necessary services and facilities are available, where aircraft performance requirements can be met and which is operational at the expected time of use. Alternate aerodromes include the following:

Take-off alternate. An alternate aerodrome at which an aircraft would be able to land should this become necessary shortly after take-off and it is not possible to use the aerodrome of departure.

En-route alternate. An alternate aerodrome at which an aircraft would be able to land in the event that a diversion becomes necessary while en route.

Destination alternate. An alternate aerodrome at which an aircraft would be able to land should it become either impossible or inadvisable to land at the aerodrome of intended landing.

Note.— The aerodrome from which a flight departs may also be an en-route or a destination alternate aerodrome for that flight.

Altimetry system error (ASE). The difference between the altitude indicated by the altimeter display, assuming a correct altimeter barometric setting, and the pressure altitude corresponding to the undisturbed ambient pressure.

Appropriate airworthiness requirements. The comprehensive and detailed airworthiness codes established, adopted or accepted by a Contracting State for the class of aircraft, engine or propeller under consideration.

Area navigation (RNAV). A method of navigation which permits aircraft operation on any desired flight path within the coverage of ground- or spaced-based navigation aids or within the limits of the capability of self-contained aids, or a combination of these.

Note.— Area navigation includes performance-based navigation as well as other operations that do not meet the definition of performance-based navigation.

Basic aircraft. An aircraft which has the minimum equipment required to perform the intended take-off, approach or landing operation.

Cabin crew member. A crew member who performs, in the interest of safety of passengers, duties assigned by the operator or the pilot-in-command of the aircraft, but who shall not act as a flight crew member.

Combined vision system (CVS). A system to display images from a combination of an enhanced vision system (EVS) and a synthetic vision system (SVS).

Commercial air transport operation. An aircraft operation involving the transport of passengers, cargo or mail for remuneration or hire.

Continuing airworthiness. The set of processes by which an aircraft, engine, propeller or part complies with the applicable airworthiness requirements and remains in a condition for safe operation throughout its operating life.

Continuing airworthiness records. Records which are related to the continuing airworthiness status of an aircraft, engine, propeller or associated part.

Continuous descent final approach (CDFA). A technique, consistent with stabilized approach procedures, for flying the final approach segment (FAS) of an instrument non-precision approach (NPA) of a non-precision instrument approach procedure as a continuous descent, without level-off, from an altitude/height at or above the final approach fix altitude/height to a point approximately 15 m (50 ft) above the landing runway threshold or the point where the flare manoeuvre begins for the type of aircraft flown; for the FAS of an NPA procedure followed by a circling approach, the CDFA technique applies until circling approach minima (circling OCA/H) or visual flight manoeuvre altitude/height are reached.

Corporate aviation operation. The non-commercial operation or use of aircraft by a company for the carriage of passengers or goods as an aid to the conduct of company business, flown by a professional pilot(s) employed to fly the aircraft.

Dangerous goods. Articles or substances which are capable of posing a risk to health, safety, property or the environment and which are shown in the list of dangerous goods in the Technical Instructions or which are classified according to those Instructions.

Note.— Dangerous goods are classified in Annex 18, Chapter 3.

Decision altitude (DA) or decision height (DH). A specified altitude or height in a 3D instrument approach operation at which a missed approach must be initiated if the required visual reference to continue the approach has not been established.

Note 1.— Decision altitude (DA) is referenced to mean sea level and decision height (DH) is referenced to the threshold elevation.

Note 2.— The required visual reference means that section of the visual aids or of the approach area which should have been in view for sufficient time for the pilot to have made an assessment of the aircraft position and rate of change of position, in relation to the desired flight path. In Category III operations with a decision height the required visual reference is that specified for the particular procedure and operation.

Note 3.— For convenience where both expressions are used they may be written in the form “decision altitude/height” and abbreviated “DA/H”.

Electronic flight bag (EFB). An electronic information system, comprised of equipment and applications for flight crew, which allows for the storing, updating, displaying and processing of EFB functions to support flight operations or duties.

Emergency locator transmitter (ELT). A generic term describing equipment which broadcast distinctive signals on designated frequencies and, depending on application, may be automatically activated by impact or be manually activated. An ELT may be any of the following:

Automatic fixed ELT (ELT(AF)). An automatically activated ELT which is permanently attached to an aircraft.

Automatic portable ELT (ELT(AP)). An automatically activated ELT which is rigidly attached to an aircraft but readily removable from the aircraft.

Automatic deployable ELT (ELT(AD)). An ELT which is rigidly attached to an aircraft and which is automatically deployed and activated by impact, and, in some cases, also by hydrostatic sensors. Manual deployment is also provided.

Survival ELT (ELT(S)). An ELT which is removable from an aircraft, stowed so as to facilitate its ready use in an emergency, and manually activated by survivors.

Engine. A unit used or intended to be used for aircraft propulsion. It consists of at least those components and equipment necessary for functioning and control, but excludes the propeller/rotors (if applicable).

Enhanced vision system (EVS). A system to display electronic real-time images of the external scene achieved through the use of image sensors.

Note.— *EVS does not include night vision imaging systems (NVIS).*

Extended flight over water. A flight operated over water at a distance of more than 93 km (50 NM), or 30 minutes at normal cruising speed, whichever is the lesser, away from land suitable for making an emergency landing.

Final approach segment (FAS). That segment of an instrument approach procedure in which alignment and descent for landing are accomplished.

Flight crew member. A licensed crew member charged with duties essential to the operation of an aircraft during a flight duty period.

Flight manual. A manual, associated with the certificate of airworthiness, containing limitations within which the aircraft is to be considered airworthy, and instructions and information necessary to the flight crew members for the safe operation of the aircraft.

Flight plan. Specified information provided to air traffic services units, relative to an intended flight or portion of a flight of an aircraft.

Flight recorder. Any type of recorder installed in the aircraft for the purpose of complementing accident/incident investigation.

Automatic deployable flight recorder (ADFR). A combination flight recorder installed on the aircraft which is capable of automatically deploying from the aircraft.

Flight simulation training device. Any one of the following three types of apparatus in which flight conditions are simulated on the ground:

A flight simulator, which provides an accurate representation of the flight deck of a particular aircraft type to the extent that the mechanical, electrical, electronic, etc. aircraft systems control functions, the normal environment of flight crew members, and the performance and flight characteristics of that type of aircraft are realistically simulated;

A flight procedures trainer, which provides a realistic flight deck environment, and which simulates instrument responses, simple control functions of mechanical, electrical, electronic, etc. aircraft systems, and the performance and flight characteristics of aircraft of a particular class;

A *basic instrument flight trainer*, which is equipped with appropriate instruments, and which simulates the flight deck environment of an aircraft in flight in instrument flight conditions.

Flight time — aeroplanes. The total time from the moment an aeroplane first moves for the purpose of taking off until the moment it finally comes to rest at the end of the flight.

Note.— *Flight time as here defined is synonymous with the term “block to block” time or “chock to chock” time in general usage which is measured from the time an aeroplane first moves for the purpose of taking off until it finally stops at the end of the flight.*

General aviation operation. An aircraft operation other than a commercial air transport operation or an aerial work operation.

Head-up display (HUD). A display system that presents flight information into the pilot's forward external field of view.

Industry codes of practice. Guidance material developed by an industry body, for a particular sector of the aviation industry to comply with the requirements of the Civil Aviation Authority of Bangladesh's Standards and Recommended Practices, other aviation safety requirements and the best practices deemed appropriate.

Note.— *Some States accept and reference industry codes of practice in the development of regulations to meet the requirements of ANO 6-2, Part II, and make available, for the industry codes of practice, their sources and how they may be obtained.*

Instrument approach operations. An approach and landing using instruments for navigation guidance based on an instrument approach procedure. There are two methods for executing instrument approach operations:

- a) a two-dimensional (2D) instrument approach operation, using lateral navigation guidance only; and
- b) a three-dimensional (3D) instrument approach operation, using both lateral and vertical navigation guidance.

Note.— *Lateral and vertical navigation guidance refers to the guidance provided either by:*

- a) a ground-based radio navigation aid; or
- b) computer-generated navigation data from ground-based, space-based, self-contained navigation aids or a combination of these.

Instrument approach procedure (IAP). A series of predetermined manoeuvres by reference to flight instruments with specified protection from obstacles from the initial approach fix, or where applicable, from the beginning of a defined arrival route to a point from which a landing can be completed and thereafter, if a landing is not completed, to a position at which holding or en-route obstacle clearance criteria apply. Instrument approach procedures are classified as follows:

Non-precision approach (NPA) procedure. An instrument approach procedure designed for 2D instrument approach operations Type A.

Note.—Non-precision approach procedures may be flown using a continuous descent final approach (CDFA) technique. CDFAs with advisory vertical navigation (VNAV) guidance calculated by on-board equipment are considered 3D instrument approach operations. CDFAs with manual calculation of the required rate of descent are considered 2D instrument approach operations. For more information on CDFAs, refer to PANS-OPS (Doc 8168), Volume I, Part II, Section 5.

Approach procedure with vertical guidance (APV). A performance-based navigation (PBN) instrument approach procedure designed for 3D instrument approach operations Type A.

Precision approach (PA) procedure. An instrument approach procedure based on navigation systems (ILS, MLS, GLS and SBAS CAT I) designed for 3D instrument approach operations Type A or B.

Note: Refer to Section 2, Chapter 2.2, 2.2.2.2.2, for instrument approach operation types.

Instrument meteorological conditions (IMC). Meteorological conditions expressed in terms of visibility, distance from cloud, and ceiling,* less than the minima specified for visual meteorological conditions.

Note. The specified minima for visual meteorological conditions are contained in Chapter 4 of ANO 2.

Isolated aerodrome. A destination aerodrome for which there is no destination alternate aerodrome suitable for a given aeroplane type.

Large aeroplane. An aeroplane of a maximum certificated take-off mass of over 5 700 kg.

*As defined in ANO-2.

Low-visibility operations (LVO). Approach operations in RVRs less than 550 m and/or with a DH less than 60 m (200 ft) or take-off operations in RVRs less than 400 m.

Maintenance. The performance of tasks on an aircraft, engine, propeller or associated part required to ensure the continuing airworthiness of an aircraft, engine, propeller or associated part including any one or combination of overhaul, inspection, replacement, defect rectification, and the embodiment of a modification or repair.

Maintenance programme. A document which describes the specific scheduled maintenance tasks and their frequency of completion and related procedures, such as a reliability programme, necessary for the safe operation of those aircraft to which it applies.

Maintenance release. A document which contains a certification confirming that the maintenance work to which it relates has been completed in a satisfactory manner, either in accordance with the approved data and the procedures described in the maintenance organization's procedures manual or under an equivalent system.

Maintenance release. A document which contains a certification confirming that the maintenance work to which it relates has been completed in a satisfactory manner in accordance with appropriate airworthiness requirements.

Meteorological information. Meteorological report, analysis, forecast, and any other statement relating to existing or expected meteorological conditions.

Minimum descent altitude (MDA) or minimum descent height (MDH). A specified altitude or height in a 2D instrument approach operation or circling approach operation below which descent must not be made without the required visual reference.

Note 1.— Minimum descent altitude (MDA) is referenced to mean sea level and minimum descent height (MDH) is referenced to the aerodrome elevation or to the threshold elevation if that is more than 2 m (7 ft) below the aerodrome elevation. A minimum descent height for a circling approach is referenced to the aerodrome elevation.

Note 2.— The required visual reference means that section of the visual aids or of the approach area which should have been in view for sufficient time for the pilot to have made an assessment of the aircraft position and rate of change of position, in relation to the desired flight path. In the case of a circling approach the required visual reference is the runway environment.

Note 3.— For convenience when both expressions are used they may be written in the form "minimum descent altitude/height" and abbreviated "MDA/H".

Modification. A change to the type design of an aircraft, engine or propeller.

Note.— *A modification may also include the embodiment of the modification which is a maintenance task subject to a maintenance release. Further guidance on aircraft maintenance — modification and repair is contained in the Airworthiness Manual (Doc 9760).*

Navigation specification. A set of aircraft and flight crew requirements needed to support performance-based navigation operations within a defined airspace. There are two kinds of navigation specifications:

Required navigation performance (RNP) specification. A navigation specification based on area navigation that includes the requirement for performance monitoring and alerting, designated by the prefix RNP, e.g. RNP 4, RNP APCH.

Area navigation (RNAV) specification. A navigation specification based on area navigation that does not include the requirement for performance monitoring and alerting, designated by the prefix RNAV, e.g. RNAV 5, RNAV 1.

Note 1.— *The Performance-based Navigation (PBN) Manual (Doc 9613), Volume II, contains detailed guidance on navigation specifications*

Note 2.— *The term RNP in this ANO is now solely used in the context of navigation specifications that require performance monitoring and alerting, e.g. RNP 4 refers to the aircraft and operating requirements, including a 4 NM lateral performance with on-board performance monitoring and alerting that are detailed in Doc 9613.*

Night. The hours between the end of evening civil twilight and the beginning of morning civil twilight or such other period between sunset and sunrise, as may be prescribed by the appropriate authority.

Note.— *Civil twilight ends in the evening when the centre of the sun's disc is 6 degrees below the horizon and begins in the morning when the centre of the sun's disc is 6 degrees below the horizon.*

Obstacle clearance altitude (OCA) or obstacle clearance height (OCH). The lowest altitude or the lowest height above the elevation of the relevant runway threshold or the aerodrome elevation as applicable, used in establishing compliance with appropriate obstacle clearance criteria.

Note 1.— *Obstacle clearance altitude is referenced to mean sea level and obstacle clearance height is referenced to the threshold elevation or in the case of non-precision approach procedures to the aerodrome elevation or the threshold elevation if that is more than 2 m (7 ft) below the aerodrome elevation. An obstacle clearance height for a circling approach procedure is referenced to the aerodrome elevation.*

Note 2.— *For convenience when both expressions are used they may be written in the form "obstacle clearance altitude/height" and abbreviated "OCA/H".*

Operating base. The location from which operational control is exercised.

Note.— *An operating base is normally the location where personnel involved in the operation of the aeroplane work and the records associated with the operation are located. An operating base has a degree of permanency beyond that of a regular point of call.*

Operational control. The exercise of authority over the initiation, continuation, diversion or termination of a flight in the interest of the safety of the aircraft and the regularity and efficiency of the flight.

Operational credit. A credit authorized for operations with an advanced aircraft enabling a lower aerodrome operating minimum than would normally be authorized for a basic aircraft, based upon the performance of advanced aircraft systems utilizing the available external infrastructure.

Operational flight plan. The operator's plan for the safe conduct of the flight based on considerations of aeroplane performance, other operating limitations and relevant expected conditions on the route to be followed and at the aerodromes concerned.

Operations manual. A manual containing procedures, instructions and guidance for use by operational personnel in the execution of their duties.

Operator. The person, organization or enterprise engaged in or offering to engage in an aircraft operation.

Note.—*In the context of ANO 6-2, Part II, the operator is not engaged in the transport of passengers, cargo or mail for remuneration or hire.*

Performance-based communication (PBC). Communication based on performance specifications applied to the provision of air traffic services.

Note.—*An RCP specification includes communication performance requirements that are allocated to system components in terms of the communication to be provided and associated transaction time, continuity, availability, integrity, safety and functionality needed for the proposed operation in the context of a particular airspace concept.*

Performance-based navigation (PBN). Area navigation based on performance requirements for aircraft operating along an ATS route, on an instrument approach procedure or in a designated airspace.

Note.— *Performance requirements are expressed in navigation specifications (RNAV specification, RNP specification) in terms of accuracy, integrity, continuity, availability and functionality needed for the proposed operation in the context of a particular airspace concept.*

Performance-based surveillance (PBS). Surveillance based on performance specifications applied to the provision of air traffic services.

Note.—An RSP specification includes surveillance performance requirements that are allocated to system components in terms of the surveillance to be provided and associated data delivery time, continuity, availability, integrity, accuracy of the surveillance data, safety and functionality needed for the proposed operation in the context of a particular airspace concept.

Pilot-in-command. The pilot designated by the operator or the owner as being in command and charged with the safe conduct of a flight.

Point of no return. The last possible geographic point at which an aircraft can proceed to the destination aerodrome as well as to an available en-route alternate aerodrome for a given flight.

Psychoactive substances. Alcohol, opioids, cannabinoids, sedatives and hypnotics, cocaine, other psychostimulants, hallucinogens, and volatile solvents, whereas coffee and tobacco are excluded.

Repair.[†] The restoration of an aeronautical product to an airworthy condition to ensure that the aircraft continues to comply with the design aspects of the appropriate airworthiness requirements used for the issuance of the type certificate for the respective aircraft type, after it has been damaged or subjected to wear.

Repair.^{††} The restoration of an aircraft, engine, propeller or associated part to an airworthy condition in accordance with the appropriate airworthiness requirements after it has been damaged or subjected to wear.

Required communication performance (RCP) specification. A set of requirements for air traffic service provision and associated ground equipment, aircraft capability, and operations needed to support performance-based communication.

Required surveillance performance (RSP) specification. A set of requirements for air traffic service provision and associated ground equipment, aircraft capability, and operations needed to support performance-based surveillance.

Runway visual range (RVR). The range over which the pilot of an aircraft on the centre line of a runway can see the runway surface markings or the lights delineating the runway or identifying its centre line.

Specific approval. An approval which is documented in the operations specifications for commercial air transport operations or in the list of specific approvals for general aviation operations.

Note.—The terms authorization, specific approval, approval and acceptance are further described in Attachment 3.D.

State of Registry. The State on whose register the aircraft is entered.

Note.—In the case of the registration of aircraft of an international operating agency on other than a national basis, the States constituting the agency are jointly and severally bound to assume the obligations which, under the Chicago Convention, attach to a CAAB. See, in this regard, the Council Resolution of 14 December 1967 on Nationality and Registration of Aircraft Operated by International Operating Agencies which can be found in Policy and Guidance Material on the Economic Regulation of International Air Transport (Doc 9587).

State of the Aerodrome. The State in whose territory the aerodrome is located.

State of the principal location of a general aviation operator. The State in which the operator of a general aviation aircraft has its principal place of business or, if there is no such place of business, its permanent residence.

Note.—Guidance concerning the options for the principal location of a general aviation operator is contained in the Manual on the Implementation of Article 83 bis of the Convention on International Civil Aviation (Doc 10059).

Synthetic vision system (SVS). A system to display data-derived synthetic images of the external scene from the perspective of the flight deck.

Target level of safety (TLS). A generic term representing the level of risk which is considered acceptable in particular circumstances.

Total vertical error (TVE). The vertical geometric difference between the actual pressure altitude flown by an aircraft and its assigned pressure altitude (flight level).

Visual meteorological conditions (VMC). Meteorological conditions expressed in terms of visibility, distance from cloud, and ceiling, * equal to or better than specified minima.

Note.—The specified minima are contained in Chapter 4 of ANO 2.

*As defined in ANO-2.

CHAPTER 1.2**APPLICABILITY**

The Provisions contained in ANO 6-2 shall be applicable to International General Aviation Operations with aeroplanes as described in Section 2 and Section 3.

Note 1.— *Provisions (Standards) applicable to the operation of aeroplanes by operators authorized to conduct international commercial air transport operations are to be found in ANO-6-1.*

Note 2.— *Provisions applicable to international commercial air transport operations or international general aviation operations with helicopters are to be found in ANO 6 -3.*

Note 3.— *Section 2 of ANO 6-2, applies to all international general aviation aeroplane operations, including those covered in Section 3. Section 3 adds additional requirements for large aeroplanes, turbojet aeroplanes and corporate aviation operations.*

ANO 6 -2**SECTION 2, GENERAL AVIATION OPERATIONS****CHAPTER 2.1 GENERAL**

Note 1.— Although the Convention on International Civil Aviation allocates to the State of Registry certain functions which that State is entitled to discharge, or obligated to discharge, as the case may be, the Assembly recognized, in Resolution A23-13, that the State of Registry may be unable to fulfil its responsibilities adequately in instances where aircraft are leased, chartered or interchanged — in particular without crew — by the operator of another State and that the Convention may not adequately specify the rights and obligations of the State of the operator in such instances until such time as Article 83 bis of the Convention enters into force. Accordingly, the Council urged that if, in the above-mentioned instances, the State of Registry finds itself unable to discharge adequately the functions allocated to it by the Convention, it delegates to the State of the Operator, subject to acceptance by the latter State, those functions of the State of Registry that can more adequately be discharged by the State of the Operator. It was understood that pending entry into force of Article 83 bis of the Convention the foregoing action would only be a matter of practical convenience and would not affect either the provisions of the Chicago Convention prescribing the duties of the State of Registry or any third State. However, as Article 83 bis of the Convention entered into force on 20 June 1997, such transfer agreements will have effect in respect of Contracting States which have ratified the related Protocol (Doc 9318) upon fulfilment of the conditions established in Article 83 bis.

Note 2. *In the case of international operations effected jointly with aeroplanes not all of which are registered in the same Contracting State, nothing in this Part prevents the States concerned entering into an agreement for the joint exercise of the functions placed upon the State of Registry by the provisions of the relevant Annexes.*

2.1.1 Compliance with laws, regulations and procedures

2.1.1.1 The pilot-in-command shall comply with the laws, regulations, and procedures of those States in which operations are conducted.

2.1.1.2 The pilot-in-command shall be familiar with the laws, regulations, and procedures, pertinent to the performance of his or her duties, prescribed for the areas to be traversed, the aerodromes to be used, and the air navigation facilities relating thereto. The pilot-in-command shall ensure that other members of the flight crew are familiar with such of these laws, regulations, and procedures as are pertinent to the performance of their respective duties in the operation of the aeroplane.

Note. Information for pilots on flight procedure parameters and operational procedures is contained in PANS- OPS (Doc 8168), Volume I. Criteria for the construction of visual and instrument flight procedures are contained in PANS-OPS (Doc 8168), Volume II. Obstacle clearance criteria and procedures used in certain States may differ from PANS-OPS, and knowledge of these differences is important for safety reasons.

2.1.1.3 The pilot-in-command shall have responsibility for operational control.

Note: The rights and obligations of a State with respect to the operation of aeroplanes registered in that State are not affected by this provision.

2.1.1.4 If an emergency situation which endangers the safety or security of the aeroplane or persons necessitates the taking of action which involves a violation of local regulations or procedures, the pilot-in-command shall notify the CAA Bangladesh (CAAB) without delay. If required by the State in which the incident occurs, the pilot-in-command shall submit a report on any such violation to the appropriate authority of such state; in that event, the pilot-in-command shall also submit a copy of it to the CAAB. Such reports shall be submitted as soon as possible within the time as per regulations.

2.1.1.5 The pilot-in-command shall have available on board the aeroplane the essential information concerning the search and rescue services in the area over which the aeroplane will be flown.

2.1.1.6 The pilot-in-command shall ensure that flight crew members demonstrate the ability to speak and understand the language used for aeronautical radiotelephony communications as specified in ANO- 1.

2.1.2 Dangerous goods

Note 1.— Provisions for carriage of dangerous goods are contained in ANO 18. Note 2.— Article 35 of the Convention refers to certain classes of cargo restrictions.

2.1.3 Use of psychoactive substances

Note: Provisions concerning the use of psychoactive substances are contained in ANO-1 and ANO-2.

2.1.4 Specific approvals

The pilot-in-command shall not conduct operations for which a specific approval is required unless such approval has been issued by the CAAB. Specific approvals shall follow the layout and contain at least the information listed in Appendix 2.4 of this ANO.

CHAPTER 2.2 FLIGHT OPERATIONS**2.2.1 Operating facilities**

2.2.1.1 The pilot-in-command shall ensure that a flight will not be commenced unless it has been ascertained by every reasonable means available that the ground and/or water facilities including communication facilities and navigation aids available and directly required on such flight, for the safe operation of the aeroplane, are adequate for the type of operation under which the flight is to be conducted.

Note.— “Reasonable means” in this Provisions is intended to denote the use, at the point of departure, of information available to the pilot-in-command either through official information published by the aeronautical information services or readily obtainable from other sources.

2.2.1.2 *The pilot-in-command, in making a decision on the adequacy of facilities and services available at an aerodrome of intended operation, should assess the level of safety risk associated with the aircraft type and nature of the operation, in relation to the availability of rescue and firefighting services (RFFS).*

2.2.2 Operational management**2.2.2.1 Operating instructions — general**

An aeroplane shall not be taxied on the movement area of an aerodrome unless the person at the controls is an appropriately qualified pilot or:

- a) has been duly authorized by the owner or in the case where it is leased the lessee, or a designated agent;
- b) is fully competent to taxi the aeroplane;
- c) is qualified to use the radio if radio communications are required; and
- d) has received instruction from a competent person in respect of aerodrome layout, and where appropriate, information on routes, signs, marking, lights, ATC signals and instructions, phraseology and procedures, and is able to conform to the operational standards required for safe aeroplane movement at the aerodrome.

2.2.2.2 Aerodrome operating minima

2.2.2.2.1 The pilot-in-command shall establish aerodrome operating minima in accordance with criteria as specified in the AIP, for each aerodrome to be used in operations. When establishing aerodrome operating minima, any conditions that may be prescribed in the list of specific approvals shall be observed. Such minima shall not be lower than any that may be established for such aerodromes by the State of the Aerodrome, except when specifically approved by CAAB.

Note.—*This Standard does not require the State of the Aerodrome to establish aerodrome operating minima.*

2.2.2.2.1.1 CAAB shall authorize operational credit(s) for operations with aeroplanes equipped with automatic landing systems, a HUD or equivalent displays, EVS, SVS or CVS. Where the operational credit relates to low visibility operations, CAAB shall issue a specific approval. Such authorizations shall not affect the classification of the instrument approach procedure.

Note 1.—*Operational credit includes:*

- a) for the purposes of an approach ban (2.2.4.1.2), a minima below the aerodrome operating minima;
- b) reducing or satisfying the visibility requirements; or
- c) requiring fewer ground facilities as compensated for by airborne capabilities.

Note 2.—*Guidance on operational credit for aircraft equipped with automatic landing systems, a HUD or equivalent displays, EVS, SVS and CVS is contained in Attachment 2.B and in the Manual of All-Weather Operations (Doc 9365).*

Note 3.—*Information regarding a HUD or equivalent displays, including references to RTCA and EUROCAE documents, is contained in the Manual of All-Weather Operations (Doc 9365).*

2.2.2.2.1.2 When issuing a specific approval for the operational credit, the CAAB shall ensure that the:

- a) aeroplane meets the appropriate airworthiness certification requirements;
- b) information necessary to support effective crew tasks for the operation is appropriately available to both pilots where the number of flight crew members specified in the operations manual (or other documents associated with the certificate of airworthiness) is more than one;

- c) operator/owner has carried out a safety risk assessment of the operations supported by the equipment;
- d) operator/owner has established and documented normal and abnormal procedures and MEL;
- e) operator/owner has established a training programme for the flight crew members and relevant personnel involved in the flight preparation;
- f) operator/owner has established a system for data collection, evaluation and trend monitoring for low visibility operations for which there is an operational credit; and
- g) operator/owner has instituted appropriate procedures with respect to continuing airworthiness (maintenance and repair) practices and programmes.

Note 1.— *Guidance on safety risk assessments is contained in the CAAB Guidance Material on SMS and ICAO Safety Management Manual (Doc 9859).*

Note 2.— *Guidance on operational approvals is contained in the Manual of All-Weather Operations (Doc 9365).*

2.2.2.2.1.3 For operations with operational credit with minima above those related to low visibility operations, the CAAB shall establish criteria for the safe operation of the aeroplane.

Note.— *Guidance on operational credit for operations with minima above those related to low visibility operations is contained in the Manual of All-Weather Operations (Doc 9365)*

2.2.2.2.2 Instrument approach operations shall be classified based on the designed lowest operating minima below which an approach operation shall only be continued with the required visual reference as follows:

- a) Type A: a minimum descent height or decision height at or above 75 m (250 ft); and
- b) Type B: a decision height below 75 m (250 ft). Type B instrument approach operations are categorized as:
 - 1) Category I (CAT I): a decision height not lower than 60 m (200 ft) and with either a visibility not less than 800 m or a runway visual range not less than 550 m;
 - 2) Category II (CAT II): a decision height lower than 60 m (200 ft) but not lower than 30 m (100 ft) and a runway visual range not less than 300 m;
 - 3) Category III (CAT III): a decision height lower than 30 m (100 ft) or no decision height and a runway visual range less than 300 m or no runway visual range limitations;

Note 1.— Where decision height (DH) and runway visual range (RVR) fall into different categories of operation, the instrument approach operation would be conducted in accordance with the requirements of the most demanding category (e.g. an operation with a DH in the range of CAT III but with an RVR in the range of CAT III would be considered a CAT III operation or an operation with a DH in the range of CAT II but with an RVR in the range of CAT I would be considered a CAT II operation). This does not apply if the RVR and/or DH has been approved as operational credits.

Note 2.— The required visual reference means that section of the visual aids or of the approach area which should have been in view for sufficient time for the pilot to have made an assessment of the aircraft position and rate of change of position, in relation to the desired flight path. In the case of a circling approach operation, the required visual reference is the runway environment.

Note 3.— Guidance on approach classification as it relates to instrument approach operations, procedures, runways and navigation systems is contained in the Manual of All- Weather Operations (Doc 9365).

2.2.2.2.3 The operating minima for 2D instrument approach operations using instrument approach procedures shall be determined by establishing a minimum descent altitude (MDA) or minimum descent height (MDH), minimum visibility and, if necessary, cloud conditions.

Note.— For guidance on applying a continuous descent final approach (CDFA) flight technique on non- precision approach procedures, refer to PANS-OPS (Doc 8168), Volume I, Part II, Section 5.

2.2.2.2.4 The operating minima for 3D instrument approach operations using instrument approach procedures shall be determined by establishing a decision altitude (DA) or decision height (DH) and the minimum visibility or RVR.

2.2.2.2.5 CAAB shall issue a specific approval for instrument approach operations in low visibility which shall only be conducted when RVR information is provided.

Note.—Guidance on low visibility operations is contained in the Manual of All-Weather Operations (Doc 9365).

2.2.2.2.6 For take-off in low visibility, CAAB shall issue a specific approval for the minimum take-off RVR.

Note.— In general, visibility for take-off is defined in terms of RVR. An equivalent horizontal visibility may also be used.

2.2.2.3 Passengers

2.2.2.3.1 The pilot-in-command shall ensure that passengers are made familiar with the location and use of:

- a) seat belts;
- b) emergency exits;
- c) life jackets, if the carriage of life jackets is prescribed;
- d) oxygen dispensing equipment if the use of oxygen is anticipated; and
- e) other emergency equipment provided for individual use, including passenger emergency briefing cards.

2.2.2.3.2 The pilot-in-command shall ensure that all persons on board are aware of the location and general manner of use of the principal emergency equipment carried for collective use.

2.2.2.3.3 In an emergency during flight, the pilot-in-command shall ensure that passengers are instructed in such emergency action as may be appropriate to the circumstances.

2.2.2.3.4 The pilot-in-command shall ensure that, during take-off and landing and whenever considered necessary by reason of turbulence or any emergency occurring during flight, all passengers on board an aeroplane shall be secured in their seats by means of the seat belts or harnesses provided.

2.2.3 Flight preparation

2.2.3.1 A flight shall not be commenced until the pilot-in-command is satisfied that:

- a) the aeroplane is airworthy, duly registered and that appropriate certificates with respect thereto are aboard the aeroplane;
- b) the instruments and equipment installed in the aeroplane are appropriate, taking into account the expected flight conditions;

- c) any necessary maintenance has been performed in accordance with Chapter 2.6;
- d) the mass of the aeroplane and centre of gravity location are such that the flight can be conducted safely, taking into account the flight conditions expected;
- e) any load carried is properly distributed and safely secured; and
- f) the aeroplane operating limitations, contained in the flight manual, or its equivalent, will not be exceeded.

2.2.3.2 *The pilot-in-command should have sufficient information on climb performance with all engines operating to enable determination of the climb gradient that can be achieved during the departure phase for the existing take-off conditions and intended take-off technique.*

2.2.3.3 Flight planning

Before commencing a flight, the pilot-in-command shall be familiar with all available meteorological information appropriate to the intended flight. Preparation for a flight away from the vicinity of the place of departure, and for every flight under the instrument flight rules, shall include:

- a) a study of available current weather reports and forecasts; and
- b) the planning of an alternative course of action to provide for the eventuality that the flight cannot be completed as planned, because of weather conditions.

Note 1.— *It is the practice in some States to declare, for flight planning purposes, higher minima for an aerodrome when nominated as an alternate, than for the same aerodrome when planned as that of intended landing.*

Note 2.— *The requirements for flight plans are contained in ANO 2 — Rules of the Air and Procedures for Air Navigation Services — Air Traffic Management (PANS-ATM, Doc 4444).*

2.2.3.4 Meteorological conditions

2.2.3.4.1 A flight to be conducted in accordance with VFR shall not be commenced unless current meteorological reports or a combination of current reports and forecasts indicate that the meteorological conditions along the route or that part of the route to be flown under VFR will, at the appropriate time, be such as to enable compliance with these rules.

2.2.3.4.2 A flight to be conducted in accordance with the instrument flight rules shall not:

- a) take off from the departure aerodrome unless the meteorological conditions, at the time of use, are at or above the aerodrome operating minima for that operation; and
- b) take off or continue beyond the point of in-flight re-planning unless at the aerodrome of intended landing or at each alternate aerodrome to be selected in compliance with 2.2.3.5, current meteorological reports or a combination of current reports and forecasts indicate that the meteorological conditions will be, at the estimated time of use, at or above the aerodrome operating minima for that operation.

2.2.3.4.3 Time margin for “estimated time of use” shall be one hour before and after the earliest and latest time of arrival.

Note.—Additional considerations can be found in the Flight Planning and Fuel Management (FPFM) Manual (Doc 9976).

2.2.3.4.4 A flight to be operated in known or expected icing conditions shall not be commenced unless the aeroplane is certificated and equipped to cope with such conditions.

2.2.3.4.5 A flight to be planned or expected to operate in suspected or known ground icing conditions shall not take off unless the aeroplane has been inspected for icing and, if necessary, has been given appropriate de-icing/anti-icing treatment. Accumulation of ice or other naturally occurring contaminants shall be removed so that the aeroplane is kept in an airworthy condition prior to take-off.

Note.— Guidance material is given in the Manual of Aircraft Ground De-icing/Anti-icing Operations (Doc 9640).

2.2.3.5 Alternate aerodromes

Destination alternate aerodromes

For a flight to be conducted in accordance with the instrument flight rules, at least one destination alternate aerodrome shall be selected and specified in the flight plans, unless:

- a) the duration of the flight from the departure aerodrome, or from the point of in-flight re-planning, to the destination aerodrome is such that, taking into account all meteorological conditions and operational information relevant to the flight, at the estimated time of use, a reasonable certainty exists that:
 - 1) the approach and landing may be made under visual meteorological conditions; and

- 2) separate runways are usable at the estimated time of use of the destination aerodrome with at least one runway having an operational instrument approach procedure; or
- b) the aerodrome of intended landing is isolated and:
- 1) a standard instrument approach procedure is prescribed for the aerodrome of intended landing;
 - 2) a point of no return has been determined; and
 - 3) a flight shall not be continued past the point of no return unless available current meteorological information indicates that the following meteorological conditions will exist at the estimated time of use:
 - i) a cloud base of at least 300 m (1 000 ft) above the minimum associated with the instrument approach procedure; and
 - ii) visibility of at least 5.5 km (3 NM) or of 4 km (2 NM) more than the minimum associated with the instrument approach procedure.

Note.—*Separate runways are two or more runways at the same aerodrome configured such that if one runway is closed, operations to the other runway(s) can be conducted.*

2.2.3.6 Fuel and oil requirements

2.2.3.6.1 A flight shall not be commenced unless, taking into account both the meteorological conditions and any delays that are expected in flight, the aeroplane carries sufficient fuel and oil to ensure that it can safely complete the flight. The amount of fuel to be carried must permit:

- a) when the flight is conducted in accordance with the instrument flight rules and a destination alternate aerodrome is not required in accordance with 2.2.3.5, or when the flight is to an isolated aerodrome, flight to the aerodrome of intended landing, and after that, have a final reserve fuel for at least 45 minutes at normal cruising altitude; or

- b) when the flight is conducted in accordance with the instrument flight rules and a destination alternate aerodrome is required, flight to the aerodrome of intended landing, then to an alternate aerodrome, and after that, have a final reserve fuel for at least 45 minutes at normal cruising altitude; or
- d) when the flight is conducted in accordance with day VFR, flight to the aerodrome of intended landing, and after that, have a final reserve fuel for at least 30 minutes at normal cruising altitude; or
- d) when the flight is conducted in accordance with night VFR, flight to the aerodrome of intended landing and thereafter have a final reserve fuel for at least 45 minutes at normal cruising altitude.

Note 1.— *Nothing in 2.2.3.6 precludes amendment of a flight plan in flight in order to replan the flight to another aerodrome, provided that the requirements of 2.2.3.6 can be complied with from the point where the flight is replanned.*

Note 2.— *Guidance on planning operations to isolated aerodromes is contained in the Flight Planning and Fuel Management (FPFM) Manual (Doc 9976).*

2.2.3.6.2 The use of fuel after flight commencement for purposes other than originally intended during pre-flight planning shall require a re-analysis and, if applicable, adjustment of the planned operation.

2.2.3.7 Refuelling with passengers on board

2.2.3.7.1 *An aeroplane should not be refueled when passengers are embarking, on board or disembarking unless it is attended by the pilot-in-command or other qualified personnel ready to initiate and direct an evacuation of the aeroplane by the most practical and expeditious means available.*

2.2.3.7.2 *When refuelling with passengers embarking, on board or disembarking, two-way communications should be maintained by the aeroplane's intercommunication system or other suitable means between the ground crew supervising the refuelling and the pilot-in-command or other qualified personnel required by 2.2.3.7.1.*

Note 1.— *The provisions of 2.2.3.7.1 do not necessarily require the deployment of integral aeroplane stairs or the opening of emergency exits as a prerequisite to refuelling.*

Note 2.— *Provisions concerning aircraft refuelling are contained in ANO 14, Volume I, and guidance on safe refuelling practices is contained in the Airport Services Manual (Doc 9137), Parts 1 and 8.*

Note 3.— *Additional precautions are required when refuelling with fuels other than aviation kerosene or when refuelling results in a mixture of aviation kerosene with other aviation turbine fuels, or when an open line is used.*

2.2.3.8 Oxygen supply

The pilot-in-command shall ensure that breathing oxygen is available to crew members and passengers in sufficient quantities for all flights at such altitudes where a lack of oxygen might result in impairment of the faculties of crew members or harmfully affect passengers.

Note 1.— *Guidance on the carriage and use of oxygen is given in Attachment 2.A.*

Note 2.— *Approximate altitudes in the Standard Atmosphere corresponding to the values of absolute pressure used in the text of Attachment 2.A are as follows:*

Absolute pressure	Metres	Feet
700 hPa	3 000	10 000
620 hPa	4 000	13 000
376 hPa	7 600	25 000

2.2.4 In-flight procedures

2.2.4.1 Aerodrome operating minima

2.2.4.1.1 A flight shall not be continued towards the aerodrome of intended landing, unless the latest available information indicates that at the expected time of arrival, a landing can be effected at that aerodrome or at least one destination alternate aerodrome, in compliance with the operating minima established in accordance with 2.2.2.2.

2.2.4.1.2 An instrument approach shall not be continued below 300 m (1000 ft) above the aerodrome elevation or into the final approach segment unless the reported visibility or controlling RVR is at or above the aerodrome operating minima.

Note.— *Criteria for the final approach segment is contained in PANS-OPS (Doc 8168), Volume II.*

2.2.4.1.3 If, after entering the final approach segment or after descending below 300 m (1000 ft) above the aerodrome elevation, the reported visibility or controlling RVR falls below the specified minimum, the approach may be continued to DA/H or MDA/H. In any case, an aeroplane shall not continue its approach-to-land beyond a point at which the limits of the aerodrome operating minima would be infringed.

Note.— *Controlling RVR means the reported values of one or more RVR reporting locations (touchdown, midpoint and stop-end) used to determine whether operating minima are or are not met. Where RVR is used, the controlling RVR is the touchdown RVR, unless otherwise specified by State criteria.*

2.2.4.2 Meteorological and operational observations by pilots

2.2.4.2.1 When meteorological conditions likely to affect the safety of other aircraft are encountered, they shall be reported as soon as possible.

Note.— *The procedures for making meteorological observations on board aircraft in flight and for recording and reporting them are contained in ANO 3, the PANS-ATM (Doc 4444) and the appropriate Regional Supplementary Procedures (Doc 7030).*

Note.— *The procedures for making special air-reports regarding runway braking action are contained in the PANS-ATM (Doc 4444), Chapter 4, and Appendix 1.*

2.2.4.3 Hazardous flight conditions

Hazardous flight conditions encountered, other than those associated with meteorological conditions, should be reported to the appropriate aeronautical station as soon as possible. The reports so rendered should give such details as may be pertinent to the safety of other aircraft.

2.2.4.4 Aeroplane operating procedures for landing performance

An approach to land should not be continued below 300 m (1000 ft) above aerodrome elevation unless the pilot-in-command is satisfied that, with the runway surface condition information available, the aeroplane performance information indicates that a safe landing can be made.

Note 1.— *The procedures for using runway surface condition information on board aircraft are contained in the PANS Aerodromes (Doc 9981) and in the performance section of the aeroplane flight manual; and for aeroplanes certificated in accordance with ANO AW (Part 21), in the Aeroplane Performance Manual (Doc 10064).*

Note 2.— *Guidance on development of aeroplane performance information for aeroplanes certificated in accordance with ANO 8, (Part 21) is contained in the Aeroplane Performance Manual (Doc 10064).*

2.2.4.5 Flight crew members at duty stations

2.2.4.4.1 **Take-off and landing.** All flight crew members required to be on flight deck duty shall be at their stations.

2.2.4.4.2 **En route.** All flight crew members required to be on flight deck duty shall remain at their stations except when their absence is necessary for the performance of duties in connection with the operation of the aeroplane or for physiological needs.

2.2.4.4.3 **Seat belts.** All flight crew members shall keep their seat belts fastened when at their stations.

2.2.4.4.4 **Safety harness.** When safety harnesses are provided, any flight crew member occupying a pilot's seat shall keep the safety harness fastened during the take-off and landing phases; all other flight crew members shall keep their safety harnesses fastened during the take-off and landing phases unless the shoulder straps interfere with the performance of their duties, in which case the shoulder straps may be unfastened but the seat belt must remain fastened.

Note.—Safety harness includes shoulder strap(s) and a seat belt which may be used independently.

2.2.4.6 Use of oxygen

All flight crew members, when engaged in performing duties essential to the safe operation of an aeroplane in flight, shall use breathing oxygen continuously whenever the circumstances prevail for which its supply has been prescribed in 2.2.3.8.

2.2.4.7 Safeguarding of cabin crew and passengers in pressurized aeroplanes in the event of loss of pressurization

Cabin crew should be safeguarded so as to ensure reasonable probability of their retaining consciousness during any emergency descent which may be necessary in the event of loss of pressurization and, in addition, they shall have such means of protection as will enable them to administer first aid to passengers during stabilized flight following the emergency. Passengers shall be safeguarded by such devices or operational procedures as will ensure reasonable probability of their surviving the effects of hypoxia in the event of loss of pressurization.

Note.— It is not envisaged that cabin crew will always be able to provide assistance to passengers during emergency descent procedures which may be required in the event of loss of pressurization.

2.2.4.8 In-flight fuel management

2.2.4.8.1 The pilot-in-command shall monitor the amount of usable fuel remaining on board to ensure it is not less than the fuel required to proceed to an aerodrome where a safe landing can be made with the planned final reserve fuel remaining.

2.2.4.8.2 The pilot-in-command shall advise ATC of a minimum fuel state by declaring MINIMUM FUEL when, having committed to land at a specific aerodrome, the pilot calculates that any change to the existing clearance to that aerodrome, or other air traffic delays, may result in landing with less than the planned final reserve fuel.

Note.— *The declaration of MINIMUM FUEL informs ATC that all planned aerodrome options have been reduced to a specific aerodrome of intended landing and any change to the existing clearance, or air traffic delays, may result in landing with less than the planned final reserve fuel. This is not an emergency situation but an indication that an emergency situation is possible should any additional delay occur.*

2.2.4.8.3 The pilot-in-command shall declare a situation of fuel emergency by broadcasting MAYDAY MAYDAY MAYDAY FUEL, when the calculated usable fuel estimated to be available upon landing at the nearest aerodrome where a safe landing can be made is less than the planned final reserve fuel.

Note 1.— *The planned final reserve fuel refers to the value calculated in 2.2.3.6 and is the minimum amount of fuel required upon landing at any aerodrome.*

Note 2.— *The words “MAYDAY FUEL” describe the nature of the distress conditions as required in ANO-10, Volume II, 5.3.2.1.1, b) 3).*

2.2.4.9 Instrument approach procedures

2.2.4.9.1 One or more instrument approach procedures designed to support instrument approach operations shall be approved and promulgated by the State in which the aerodrome is located to serve each instrument runway or aerodrome utilized for instrument flight operations.

2.2.4.9.2 Aeroplanes operated in accordance with the instrument flight rules shall comply with the instrument approach procedures approved by the State in which the aerodrome is located.

Note 1.— *See 2.2.2.2.1 for instrument approach operation classifications.*

Note 2.— *Information for pilots on flight procedure parameters and operational procedures is contained in PANS-OPS, Volume I. Criteria for the construction of visual and instrument flight procedures are contained in PANS-OPS, Volume II. Obstacle clearance criteria and procedures used in certain States may differ from PANS-OPS, and knowledge of these differences is important for safety reasons (see 2.1.1.1).*

2.2.5 Duties of pilot-in-command

2.2.5.1 The pilot-in-command shall be responsible for the operation, safety and security of the aeroplane and the safety of all crew members, passengers and cargo on board.

2.2.5.2 The pilot-in-command shall be responsible for ensuring that a flight:

- a) will not be commenced if any flight crew member is incapacitated from performing duties by any cause such as injury, sickness, fatigue, the effects of any psychoactive substance; and
- b) will not be continued beyond the nearest suitable aerodrome when flight crew members' capacity to perform functions is significantly reduced by impairment of faculties from causes such as fatigue, sickness or lack of oxygen.

2.2.5.3 The pilot-in-command shall be responsible for notifying the nearest appropriate authority by the quickest available means of any accident involving the aeroplane, resulting in serious injury or death of any person or substantial damage to the aeroplane or property.

Note.— A definition of the term “serious injury” is contained in Aircraft Accident Investigation Order (AAIO).

2.2.6 Cabin baggage (take-off and landing)

The pilot-in-command shall ensure that all baggage carried onto an aeroplane and taken into the passenger cabin is securely stowed.

CHAPTER 2.3 AEROPLANE PERFORMANCE OPERATING LIMITATIONS

2.3.1 General

2.3.1.1 An aeroplane shall be operated:

- a) in compliance with the terms of its airworthiness certificate or equivalent approved document;
- b) within the operating limitations prescribed by the certifying authority; and
- c) if applicable, within the mass limitations imposed by compliance with the applicable noise certification Standards in ANO-16, Volume I, unless otherwise authorized in exceptional circumstances for a certain aerodrome or a runway where there is no noise disturbance problem, by the competent authority of the State in which the aerodrome is situated.

2.3.1.2 Placards, listings, instrument markings, or combinations thereof, containing those operating limitations prescribed by the CAAB for visual presentation, shall be displayed in the aeroplane.

2.3.1.3 The pilot-in-command shall determine that aeroplane performance will permit the take-off and departure to be carried out safely.

CHAPTER 2.4 AEROPLANE INSTRUMENTS, EQUIPMENT AND FLIGHT DOCUMENTS

Note.—Specifications for the provision of aeroplane communication and navigation equipment are contained in Chapter 2.5.

2.4.1 General

In addition to the minimum equipment necessary for the issuance of a certificate of airworthiness, the instruments, equipment and flight documents prescribed in the following paragraphs shall be installed or carried, as appropriate, in aeroplanes according to the aeroplane used and to the circumstances under which the flight is to be conducted. The prescribed instruments and equipment, including their installation, shall be acceptable to the CAAB.

2.4.2 Aeroplanes on all flights

2.4.2.1 An aeroplane shall be equipped with instruments which will enable the flight crew to control the flight path of the aeroplane, carry out any required procedural manoeuvres and observe the operating limitations of the aeroplane in the expected operating conditions.

2.4.2.2 An aeroplane shall be equipped with or carry on board:

- a) an accessible first-aid kit;
- b) portable fire extinguishers of a type which, when discharged, will not cause dangerous contamination of the air within the aeroplane. At least one shall be located in:
 - 1) the pilot's compartment; and
 - 2) each passenger compartment that is separate from the pilot's compartment and that is not readily accessible to the flight crew;

Note.— Refer to 2.4.2.3 for fire extinguishing agents.

- c)
 - 1) a seat or berth for each person over an age to be determined by the CAAB; and
 - 2) a seat belt for each seat and restraining belts for each berth;
- d) the following manuals, charts and information:
 - 1) the flight manual or other documents or information concerning any operating limitations prescribed for the aeroplane by the CAAB, required for the application of Chapter 2.3;

- 2) any specific approval issued by the CAAB, if applicable, for the operation(s) to be conducted;
 - 3) current and suitable charts for the route of the proposed flight and all routes along which it is reasonable to expect that the flight may be diverted;
 - 4) procedures, as prescribed in ANO-2, for pilots-in-command of intercepted aircraft;
 - 5) visual signals for use by intercepting and intercepted aircraft, as contained in ANO 2; and
 - 6) the journey log book for the aeroplane;
- e) where the aeroplane is fitted with fuses that are accessible in flight, spare electrical fuses of appropriate ratings for replacement of those fuses.

2.4.2.3 Any agent used in a built-in fire extinguisher for each lavatory disposal receptacle for towels, paper or waste in an aeroplane for which the individual certificate of airworthiness is first issued on or after 31 December 2011 and any extinguishing agent used in a portable fire extinguisher in an aeroplane for which the individual certificate of airworthiness is first issued on or after 31 December 2018 shall:

- a) meet the applicable minimum performance requirements of the CAAB; and
- b) not be of a type listed in the 1987 *Montreal Protocol on Substances that Deplete the Ozone Layer* as it appears in the Eighth Edition of the *Handbook for the Montreal Protocol on Substances that Deplete the Ozone Layer*, Annex A, Group II.

Note.—*Information concerning extinguishing agents is contained in the UNEP Halons Technical Options Committee Technical Note No. 1—New Technology Halon Alternatives and FAA Report No. DOT/FAA/AR-99-63, Options to the Use of Halons for Aircraft Fire Suppression Systems.*

2.4.2.4 *Aeroplanes on all flights should be equipped with the ground-air signal codes for search and rescue purposes.*

2.4.2.5 *Aeroplanes on all flights should be equipped with a safety harness for each flight crew member seat.*

Note.—*Safety harness includes shoulder strap(s) and a seat belt which may be used independently.*

2.4.2.6 Marking of break-in points

2.4.2.6.1 If areas of the fuselage suitable for break-in by rescue crews in emergency are marked on an aeroplane such areas shall be marked as shown below (see figure following). The colour of the markings shall be red or yellow, and if necessary they shall be outlined in white to contrast with the background.

2.4.2.6.2 If the corner markings are more than 2 m apart, intermediate lines 9 cm x 3 cm shall be inserted so that there is no more than 2 m between adjacent markings.

Note.— This provision does not require any aeroplane to have break-in areas.

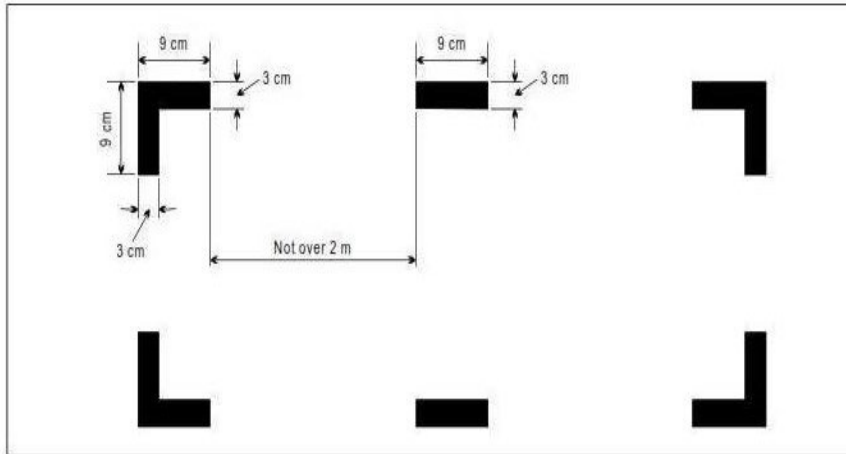

MARKING OF BREAK-IN POINTS (see-6.2.4)

2.4.3 All aeroplanes operated as VFR flights

2.4.3.1 All aeroplanes when operated as VFR flights shall be:

- a) equipped with a means of measuring and displaying:
 - 1) magnetic heading;
 - 2) barometric altitude;
 - 3) indicated airspeed;
- b) equipped with, or shall carry, a means of measuring and displaying time in hours, minutes and seconds; and c) equipped with such additional equipment as may be prescribed by the appropriate authority.

2.4.3.2 *VFR flights which are operated as controlled flights should be equipped in accordance with 2.4.7.*

2.4.4 Aeroplanes on flights over water

2.4.4.1 Seaplanes

Seaplanes for all flights shall be equipped with:

- a) one life jacket, or equivalent individual floatation device, for each person on board, stowed in a position readily accessible from the seat or berth;
- b) equipment for making the sound signals prescribed in the *International Regulations for Preventing Collisions at Sea*, where applicable;
- c) one anchor; and
- d) one sea anchor (drogue), when necessary to assist in manoeuvring.

Note.—“Seaplanes” includes amphibians operated as seaplanes.

2.4.4.2 Landplanes

Single-engined landplanes

All single-engined landplanes:

- a) when flying en route over water beyond gliding distance from the shore; or

- b) when taking off or landing at an aerodrome where, in the opinion of the pilot-in-command, the take-off or approach path is so disposed over water that in the event of a mishap there would be a likelihood of a ditching;
- c) should carry one life jacket or equivalent individual floatation device for each person on board, stowed in a position easily accessible from the seat or berth of the person for whose use it is provided.

Note.—“Landplanes” includes amphibians operated as landplanes.

2.4.4.3 Aeroplanes on extended flights over water

2.4.4.3.1 All aeroplanes operated on extended flights over water shall be equipped with, at a minimum, one life jacket or equivalent individual floatation device for each person on board, stowed in a position easily accessible from the seat or berth of the person for whose use it is provided.

2.4.4.3.2 The pilot-in-command of an aeroplane operated on an extended flight over water shall determine the risks to survival of the occupants of the aeroplane in the event of a ditching. The pilot-in-command shall take into account the operating environment and conditions such as, but not limited to, sea state and sea and air temperatures, the distance from land suitable for making an emergency landing, and the availability of search and rescue facilities. Based upon the assessment of these risks, the pilot-in-command shall, in addition to the equipment required in 2.4.4.3.1, ensure that the aeroplane is equipped with:

- a) life-saving rafts in sufficient numbers to carry all persons on board, stowed so as to facilitate their ready use in emergency, provided with such life-saving equipment, including means of sustaining life, as is appropriate to the flight to be undertaken; and
- b) equipment for making the distress signals described in ANO-2.

2.4.5 Aeroplanes on flights over designated land areas

Aeroplanes, when operated across land areas which have been designated by the State concerned as areas in which search and rescue would be especially difficult, shall be equipped with such signalling devices and life-saving equipment (including means of sustaining life) as appropriate to the area overflown.

2.4.6 Aeroplanes on high altitude flights

2.4.6.1 Aeroplanes intended to be operated at high altitudes shall be equipped with oxygen storage and dispensing apparatus capable of storing and dispensing the oxygen supplies required in 2.2.3.8.

2.4.6.2 Aeroplanes for which the individual certificate of airworthiness is first issued on or after 1 January 1990

Pressurized aeroplanes intended to be operated at flight altitudes at which the atmospheric pressure is less than 376 hPa shall be equipped with a device to provide positive warning to the flight crew of any dangerous loss of pressurization.

2.4.6.3 Aeroplanes for which the individual certificate of airworthiness was first issued before 1 January 1990

Pressurized aeroplanes intended to be operated at flight altitudes at which the atmospheric pressure is less than 376 hPa should be equipped with a device to provide positive warning to the flight crew of any dangerous loss of pressurization.

2.4.7 All aeroplanes operated in accordance with the instrument flight rules

All aeroplanes when operated in accordance with the instrument flight rules, or when the aeroplane cannot be maintained in a desired attitude without reference to one or more flight instruments, shall be:

a) equipped with a means of measuring and displaying:

- 1) magnetic heading (standby compass);
- 2) barometric altitude;
- 3) indicated airspeed, with a means of preventing malfunctioning due to either condensation or icing;
- 4) turn and slip;
- 5) aircraft attitude;
- 6) stabilized aircraft heading;

Note.— The requirements of 4), 5) and 6) may be met by combinations of instruments or by integrated flight director systems provided that the safeguards against total failure, inherent in the three separate instruments, are retained.

- 7) whether the supply of power to the gyroscopic instruments is adequate;
- 8) the outside air temperature;
- 9) rate-of-climb and descent;

- b) equipped with, or shall carry, a means of measuring and displaying time in hours, minutes and seconds; and
- c) equipped with such additional instruments or equipment as may be prescribed by the appropriate authority.

2.4.8 Aeroplanes when operated at night

Aeroplanes, when operated at night, shall be equipped with:

- a) the equipment specified in 2.4.7; and
- b) the lights required by ANO 2 for aircraft in flight or operating on the movement area of an aerodrome;

Note.— Specifications for lights meeting the requirements of ANO 2 for navigation lights are contained in Appendix 2.1. The general characteristics of lights are specified in ANO 8 (ANO AW Part 21).

- c) a landing light;
- d) illumination for all flight instruments and equipment that are essential for the safe operation of the aeroplane that are used by the flight crew;
- e) lights in all passenger compartments; and
- f) an independent portable light for each crew member station.

2.4.9 Aeroplanes complying with the noise certification Standards in ANO-16, Volume I

An aeroplane shall carry a document attesting noise certification. Refer to ANO (AW) Part-21 for applicable requirements.

Note.— The attestation may be contained in any document, carried on board, approved by the CAAB.

2.4.10 Mach number indicator

Aeroplanes with speed limitations expressed in terms of Mach number shall be equipped with a means of displaying Mach number.

2.4.11 Aeroplanes required to be equipped with ground proximity warning systems (GPWS)

2.4.11.1 All turbine-engined aeroplanes of a maximum certificated take-off mass in excess of 5700 kg or authorized to carry more than nine passengers shall be equipped with a ground proximity warning system which has a forward-looking terrain avoidance function.

2.4.11.2 *All turbine-engined aeroplanes of a maximum certificated take-off mass of 5700 kg or less and authorized to carry more than five but not more than nine passengers should be equipped with a ground proximity warning system which has a forward-looking terrain avoidance function.*

2.4.11.3 *All piston-engined aeroplanes of a maximum certificated take-off mass in excess of 5700 kg or authorized to carry more than nine passengers should be equipped with a ground proximity warning system which has a forward-looking terrain avoidance function.*

2.4.11.4 A ground proximity warning system shall provide automatically a timely and distinctive warning to the flight crew when the aeroplane is in potentially hazardous proximity to the earth's surface.

2.4.11.5 A ground proximity warning system shall provide, at a minimum, warnings of at least the following circumstances:

- a) excessive descent rate;
- b) excessive altitude loss after take-off or go-around; and
- c) unsafe terrain clearance.

2.4.11.6 A ground proximity warning system should provide, as a minimum, warnings of at least the following circumstances:

- a) *excessive descent rate;*
- b) *excessive terrain closure rate;*
- c) *excessive altitude loss after take-off or go-around;*
- d) *unsafe terrain clearance while not in landing configuration;*
 - 1) *gear not locked down;*
 - 2) *flaps not in a landing position; and*
- e) *excessive descent below the instrument glide path.*

2.4.11.7 A ground proximity warning system installed in turbine-engined aeroplanes of a maximum certificated take-off mass in excess of 5700 kg or authorized to carry more than nine passengers for which the individual certificate of airworthiness was first issued after 1 January 2011 shall provide, as a minimum, warnings of at least the following circumstances:

- a) excessive descent rate;
- b) excessive terrain closure rate;
- c) excessive altitude loss after take-off or go-around;

- d) unsafe terrain clearance while not in landing configuration;
 - 1) gear not locked down;
 - 2) flaps not in a landing position; and
- e) excessive descent below the instrument glide path.

2.4.12 Emergency locator transmitter (ELT)

2.4.12.1 All aeroplanes should carry an automatic ELT.

2.4.12.2 Except as provided for in 2.4.12.3, all aeroplanes shall be equipped with at least one ELT of any type.

2.4.12.3 All aeroplanes for which the individual certificate of airworthiness is first issued after 1 July 2008 shall be equipped with at least one automatic ELT.

2.4.12.4 ELT equipment carried to satisfy the requirements of 2.4.12.1, 2.4.12.2 and 2.4.12.3 shall operate in accordance with the relevant provisions of ANO 10, Volume III.

Note.— The judicious choice of numbers of ELTs, their type and placement on aircraft, and associated floatable life- support systems, will ensure the greatest chance of ELT activation in the event of an accident for aircraft operating over water or land, including areas especially difficult for search and rescue. Placement of transmitter units is a vital factor in ensuring optimal crash and fire protection. The placement of the control and switching devices (activation monitors) of automatic fixed ELTs and their associated operational procedures will also take into consideration the need for rapid detection of inadvertent activation and convenient manual switching by crew members.

2.4.13 Aeroplanes required to be equipped with a pressure-altitude reporting transponder

2.4.13.1 Aeroplanes shall be equipped with a pressure-altitude reporting transponder which operates in accordance with the relevant provisions of ANO 10, Volume IV.

2.4.13.2 Unless exempted by the appropriate authorities, aeroplanes operating as VFR flights shall be equipped with a pressure-altitude reporting transponder which operates in accordance with the relevant provision of ANO 10, Volume IV.

Note.— These provisions are intended to support the effectiveness of ACAS as well as to improve the effectiveness of air traffic services.

2.4.14 Microphones

When operating under the instrument flight rules all flight crew members required to be on flight deck duty should communicate through boom or throat microphones below the transition level/altitude.

2.4.15 Aeroplanes equipped with automatic landing systems, a head-up display (HUD) or equivalent displays, enhanced vision systems (EVS), synthetic vision systems (SVS) and/or combined vision systems (CVS)

Notwithstanding Chapter 2.2, 2.2.2.2.1.1 to 2.2.2.2.1.3, where aeroplanes are equipped with automatic landing systems, a HU or equivalent displays, EVS, SVS or CVS, or any combination of those systems into a hybrid system, criteria for the use of such systems for the safe operation of an aeroplane shall be established by the State of Registry.

Note.— *Information regarding automatic landing systems, a HUD or equivalent displays, EVS, SVS OR CVS, is contained in the Manual of All-Weather Operations (Doc 9365).*

2.4.16 Flight recorders

Note 1.—*Crash-protected flight recorders comprise one or more of the following:*

- *a flight data recorder (FDR),*
- *a cockpit voice recorder (CVR),*
- *an airborne image recorder (AIR),*
- *a data link recorder (DLR).*

As per Appendix 2.3, image and data link information may be recorded on either the CVR or the FDR.

Note 2.—*Lightweight flight recorders comprise one or more of the following:*

- *an aircraft data recording system (ADRS),*
- *a cockpit audio recording system (CARS),*
- *an airborne image recording system (AIRS),*
- *a data link recording system (DLRS).*

As per Appendix 2.3, image and data link information may be recorded on either the CARS or the ADRS.

Note 3.— *Detailed requirements on flight recorders are contained in Appendix 2.3.*

Note 4.— For aeroplanes for which the application for type certification is submitted to a Contracting State before 1 January 2016, specifications applicable to crash-protected flight recorders may be found in EUROCAE ED-112, ED-56A, ED-55, Minimum Operational Performance Specifications (MOPS), or earlier equivalent documents.

Note 5.— For aeroplanes for which the application for type certification is submitted to a Contracting State on or after 1 January 2016, specifications applicable to crash-protected flight recorders may be found in EUROCAE ED-112A, Minimum Operational Performance Specification (MOPS), or equivalent documents.

Note 6.— Specifications applicable to lightweight flight recorders may be found in EUROCAE ED-155, Minimum Operational Performance Specification (MOPS), or equivalent documents.

Note 7.— As of 7 November 2019, Section 3, Chapter 3.3, contains requirements for States regarding the use of voice, image and/or data recordings and transcripts.

2.4.16.1 Flight data recorders and aircraft data recording systems

Note.— Parameters to be recorded are listed in Tables A2.3-1 and A2.3-3 of Appendix 2.3.

2.4.16.1.1 Applicability

2.4.16.1.1.1 All turbine-engined aeroplanes with a seating configuration of more than five passenger seats and a maximum certificated take-off mass of 5 700 kg or less for which the individual certificate of airworthiness is first issued on or after 1 January 2016 should be equipped with:

- a) an FDR which should record at least the first 16 parameters in Table A2.3-1 of Appendix 2.3; or*
- b) a Class C AIR or AIRS which should record at least the flight path and speed parameters displayed to the pilot(s), as defined in 2.2.2 of Appendix 2.3; or c) an ADRS which should record at least the first 7 parameters listed in Table A2.3-3 of Appendix 2.3.*

Note 1.— AIR or AIRS classification is defined in 4.1 of Appendix 2.3.

Note 2.— “The application for type certification that is submitted to a Contracting State” refers to the date of application of the original “Type Certificate” for the aeroplane type, not the date of certification of particular aeroplane variants or derivative models.

2.4.16.1.1.2 All aeroplanes of a maximum certificated take-off mass of over 5700 kg for which the application for type certification is submitted to a Contracting State on or after 1 January 2023 shall be equipped with an FDR capable of recording at least the 82 parameters listed in Table A2.3-1 of Appendix 2.3.

2.4.16.1.1.3 *All aeroplanes of a maximum certificated take-off mass of over 5700 kg for which the individual certificate of airworthiness is first issued on or after 1 January 2023 should be equipped with an FDR capable of recording at least the 82 parameters listed in Table A2.3-1 of Appendix 2.3.*

2.4.16.1.2 Recording technology

FDRs, ADRS, AIRs or AIRS shall not use engraving metal foil, frequency modulation (FM), photographic film or magnetic tape.

2.4.16.1.3 Duration

All FDRs shall retain the information recorded during at least the last 25 hours of their operation.

2.4.16.2 Cockpit voice recorders and cockpit audio recording systems

2.4.16.2.1 Applicability

All turbine-engined aeroplanes with a seating configuration of more than five passenger seats and a maximum certificated take-off mass of 5 700 kg or less for which the individual certificate of airworthiness is first issued on or after 1 January 2016 and required to be operated by more than one pilot should be equipped with either a CVR or a CARS.

2.4.16.2.2 Recording technology

CVRs and CARS shall not use magnetic tape or wire.

2.4.16.2.3 Duration

2.4.16.2.3.1 All CVRs shall retain the information recorded during at least the last 2 hours of their operation.

2.4.16.2.3.2 All aeroplanes that are required to be equipped with CARS, and for which the individual certificate of airworthiness is first issued on or after 1 January 2025, shall be equipped with a CARS which shall retain the information recorded during at least the last two hours of their operation.

2.4.16.3 Data link recorders**2.4.16.3.1 Applicability**

2.4.16.3.1.1 All aeroplanes for which the individual certificate of airworthiness is first issued on or after 1 January 2016, which use any of the data link communications applications referred to in 5.1.2 of Appendix 2.3 and are required to carry a CVR, shall record the data link communications messages on a crash-protected flight recorder.

2.4.16.3.1.2 All aeroplanes for which the individual certificate of airworthiness was first issued before 1 January 2016, that are required to carry a CVR and are modified on or after 1 January 2016 to install and use any of the data link communications applications referred to in 5.1.2 of Appendix 2.3, shall record the data link communications messages on a crash-protected flight recorder, unless the installed data link communications equipment is compliant with a type certificate issued or aircraft modification first approved prior to 1 January 2016.

Note 1.—Refer to Table 3.C-4 in Attachment 3.C for examples of data link communication recording requirements.

Note 2.—A Class B AIR could be a means for recording data link communications applications messages to and from the aeroplanes where it is not practical or is prohibitively expensive to record those data link communications applications messages on FDR or CVR.

Note 3.—The “aircraft modifications” refer to modifications to install the data link communications equipment on the aircraft (e.g. structural, wiring).

2.4.16.3.1.3 All aeroplanes for which the individual certificate of airworthiness was first issued before 1 January 2016, that are required to carry a CVR and are modified on or after 1 January 2016 to use any of the data link communications applications referred to in 5.1.2 of Appendix 2.3 should record the data link communications messages on a crash-protected flight recorder.

2.4.16.3.2 Duration

The minimum recording duration shall be equal to the duration of the CVR.

2.4.16.3.3 Correlation

Data link recording shall be able to be correlated to the recorded cockpit audio.

2.4.16.4 Flight recorders — general**2.4.16.4.1 Construction and installation**

Flight recorders shall be constructed, located and installed so as to provide maximum practical protection for the recordings in order that the recorded information may be preserved, recovered and transcribed. Flight recorders shall meet the prescribed crashworthiness and fire protection specifications.

2.4.16.4.2 Operation

2.4.16.4.2.1 Flight recorders shall not be switched off during flight time.

2.4.16.4.2.2 To preserve flight recorder records, flight recorders shall be deactivated upon completion of flight time following an accident or incident. The flight recorders shall not be reactivated before their disposition as determined in accordance with Aircraft Accident Investigation Order (AAIO).

Note 1.—*The need for removal of the flight recorder records from the aircraft will be determined by the investigation authority in the State conducting the investigation with due regard to the seriousness of an occurrence and the circumstances, including the impact on the operation.*

Note 2.—*The pilot-in-command's responsibilities regarding the retention of flight recorder records are contained in 2.4.16.4.3.*

2.4.16.4.3 Flight recorder records

The pilot-in-command, and/or the owner/operator, shall ensure, to the extent possible, in the event the aeroplane becomes involved in an accident or incident, the preservation of all related flight recorder records, and if necessary the associated flight recorders, and their retention in safe custody pending their disposition as determined in accordance with Aircraft Accident Investigation Order (AAIO).

2.4.16.4.4 Continued serviceability

Operational checks and evaluations of recordings from the flight recorder systems shall be conducted to ensure the continued serviceability of the recorders.

Note.— *Procedures for the inspections of the flight recorder systems are given in Appendix 2.3.*

2.4.16.4.5 Flight recorder electronic documentation

The documentation requirement concerning FDR and ADRS parameters provided by operators to accident investigation authorities should be in electronic format and take account of industry specifications.

Note.— *Industry specifications for documentation concerning flight recorder parameters may be found in ARINC 647A, Flight Recorder Electronic Documentation, or equivalent document.*

2.4.17 Electronic flight bags (EFBs)

Note.— *Guidance on EFB equipment, functions and specific approval is contained in the Manual on Electronic Flight Bags (EFBs) (Doc 10020).*

2.4.17.1 EFB equipment

Where portable EFBs are used on board an aeroplane, the pilot-in-command and/or the operator/owner shall ensure that they do not affect the performance of the aeroplane systems, equipment or the ability to operate the aeroplane.

2.4.17.2 EFB functions

2.4.17.2.1 Where EFBs are used on board an aeroplane the pilot-in-command and/or the owner/operator shall:

- a) assess the safety risk(s) associated with each EFB function;
- b) establish the procedures for the use of, and training requirements for, the device and each EFB function; and
- c) ensure that, in the event of an EFB failure, sufficient information is readily available to the flight crew for the flight to be conducted safely.

Note.—*Guidance on safety risk assessments is contained in the Safety Management Manual (SMM) (Doc 9859).*

2.4.17.2.2 The CAAB shall issue a specific approval for the operational use of EFB functions to be used for the safe operation of aeroplanes.

2.4.17.3 EFB specific approval

When issuing a specific approval for the use of EFBs, the CAAB shall ensure that:

- a) the EFB equipment and its associated installation hardware, including interaction with aeroplane systems if applicable, meet the appropriate airworthiness certification requirements;
- b) the operator/owner has assessed the risks associated with the operations supported by the EFB function(s);
- c) the operator/owner has established requirements for redundancy of the information (if appropriate) contained in and displayed by the EFB function(s);
- d) the operator/owner has established and documented procedures for the management of the EFB function(s) including any databases it may use; and
- e) the operator/owner has established and documented the procedures for the use of, and training requirements for, the EFB function(s).

Note.— *2.4.18 Aeroplane operated under an Article 83 bis agreement.*

2.4.18 Aeroplane operated under an Article 83 bis agreement

Note.— Guidance concerning the transfer of responsibilities by the State of Registry to the State of the principal location of a general aviation operator in accordance with Article 83 bis is contained in the Manual on the Implementation of Article 83 bis of the Convention on International Civil Aviation (Doc 10059).

2.4.18.1 An aeroplane, when operating under an Article 83 bis agreement entered into between the State of Registry and the State of the principal location of a general aviation operator, shall carry a certified true copy of the agreement summary, in either an electronic or hard copy format. When the summary is issued in a language other than English, an English translation shall be included.

Note.— Guidance regarding the agreement summary is contained in Doc 10059.

2.4.18.2 The agreement summary of an Article 83 bis agreement shall be accessible to a civil aviation safety inspector to determine which functions and duties are transferred under the agreement by the State of Registry to the State of the principal location of a general aviation operator, when conducting surveillance activities such as ramp checks.

Note.— Guidance for the civil aviation safety inspector conducting an inspection of an aeroplane operated under an Article 83 bis agreement is contained in the Manual of Procedures for Operations Inspection, Certification and Continued Surveillance (Doc 8335).

2.4.18.3 The agreement summary shall be transmitted to ICAO together with the Article 83 bis agreement for registration with the ICAO Council by the State of Registry or the State of the principal location of a general aviation operator.

Note.— The agreement summary transmitted with the Article 83 bis agreement registered with the CAAB Council contains the list of all aircraft affected by the agreement. However, the certified true copy to be carried on board, as per 2.4.18.1, will need to list only the specific aircraft carrying the copy.

2.4.18.4 The agreement summary should contain the information in Appendix 2.5 for the specific aircraft and should follow the layout of Appendix 2.5, paragraph 2.

CHAPTER 2.5**AEROPLANE COMMUNICATION, NAVIGATION, AND SURVEILLANCE EQUIPMENT****2.5.1 Communication equipment**

2.5.1.1 An aeroplane to be operated in accordance with the instrument flight rules or at night shall be provided with radio communication equipment. Such equipment shall be capable of conducting two-way communication with those aeronautical stations and on those frequencies prescribed by the appropriate authority.

Note.— The requirements of 2.5.1.1 are considered fulfilled if the ability to conduct the communications specified therein is established during radio propagation conditions which are normal for the route.

2.5.1.2 When compliance with 2.5.1.1 requires that more than one communication equipment unit be provided, each shall be independent of the other or others to the extent that a failure in any one will not result in failure of any other.

2.5.1.3 An aeroplane to be operated in accordance with VFR, but as a controlled flight, shall, unless exempted by the appropriate authority, be provided with radio communication equipment capable of conducting two-way communication at any time during flight with such aeronautical stations and on such frequencies as may be prescribed by appropriate authority

2.5.1.4 An aeroplane to be operated on a flight to which the provisions of 2.4.4.3.1 or 2.4.5 apply shall, unless exempted by the appropriate authority, be provided with radio communication equipment capable of conducting two-way communication at any time during flight with such aeronautical stations and on such frequencies as may be prescribed by the appropriate authority.

2.5.1.5 The radio communication equipment required in accordance with 2.5.1.1 to 2.5.1.4 shall provide for communication on the aeronautical emergency frequency 121.5 MHz.

2.5.1.6 For operations where communication equipment is required to meet an RCP specification for *performance-based communication* (PBC), an aeroplane shall, in addition to the requirements specified in 2.5.1.1 to 2.5.1.5:

- a) be provided with communication equipment which will enable it to operate in accordance with the prescribed RCP specification(s);

- b) have information relevant to the aeroplane RCP specification capabilities listed in the flight manual or other aeroplane documentation approved by the State of Design or State of Registry; and
- c) where the aeroplane is operated in accordance with a MEL, have information relevant to the aeroplane RCP specification capabilities included in the MEL.

Note.—*Information on the performance-based communication and surveillance (PBCS) concept and guidance material on its implementation are contained in the Performance-based Communication and Surveillance (PBCS) Manual (Doc 9869).*

2.5.1.7 CAAB shall establish criteria for operations where an RCP specification for PBC has been prescribed.

2.5.1.8 In establishing criteria for operations where an RCP specification for PBC has been prescribed, CAAB shall require that the operator/owner establish:

- a) normal and abnormal procedures, including contingency procedures;
- b) flight crew qualification and proficiency requirements, in accordance with the appropriate RCP specifications;
- c) a training programme for relevant personnel consistent with the intended operations; and
- d) appropriate maintenance procedures to ensure continued airworthiness, in accordance with appropriate RCP specifications.

2.5.1.9 CAAB shall ensure that, in respect of those aeroplanes mentioned in 2.5.1.6, adequate provisions exist for:

- a) receiving the reports of observed communication performance issued by monitoring programmes established in accordance with ANO 11, Chapter 3, 3.3.5.2; and
- b) taking immediate corrective action for individual aircraft, aircraft types or operators, identified in such reports as not complying with the RCP specification(s).

2.5.2 Navigation equipment

2.5.2.1 An aeroplane shall be provided with navigation equipment which will enable it to proceed:

- a) in accordance with its flight plan; and
- b) in accordance with the requirements of air traffic services;

except when, if not so precluded by the appropriate authority, navigation for flights under VFR is accomplished by visual reference to landmarks.

2.5.2.2 For operations where a navigation specification for performance-based navigation (PBN) has been prescribed, an aeroplane shall, in addition to the requirements specified in 2.5.2.1:

- a) be provided with navigation equipment which will enable it to operate in accordance with the prescribed navigation specification(s); and
- b) have information relevant to the aeroplane navigation specification capabilities listed in the flight manual or other aeroplane documentation approved by the State of Design or State of Registry; and
- c) where the aeroplane is operated in accordance with a MEL, have information relevant to the aeroplane navigation specification capabilities included in the MEL.

Note.— Guidance on aeroplane documentation is contained in the Performance-based Navigation (PBN) Manual (Doc 9613).

2.5.2.3 CAAB shall establish criteria for operations where a navigation specification for PBN has been prescribed.

2.5.2.4 In establishing criteria for operations where a navigation specification for PBN has been prescribed, CAAB shall require that the operator/owner establish:

- a) normal and abnormal procedures including contingency procedures;
- b) flight crew qualification and proficiency requirements, in accordance with the appropriate navigation specifications;
- c) training for relevant personnel consistent with the intended operations; and
- d) appropriate maintenance procedures to ensure continued airworthiness, in accordance with the appropriate navigation specifications.

Note 1.— *Guidance on safety risks and mitigations for PBN operations, in accordance with ANO 19, are contained in the Performance-based Navigation (PBN) Operational Approval Manual (Doc 9997).*

Note 2.— *Electronic navigation data management is an integral part of normal and abnormal procedures.*

2.5.2.5 CAAB shall issue a specific approval for operations based on PBN authorization required (AR) navigation specifications.

Note.— *Guidance on specific approvals for PBN authorization required (AR) navigation specifications is contained in the Performance-based Navigation (PBN) Operational Approval Manual (Doc 9997).*

2.5.2.6 For flights in defined portions of airspace where, based on Regional Air Navigation Agreement, minimum navigation performance specifications (MNPS) are prescribed, an aeroplane shall be provided with navigation equipment which:

- a) continuously provides indications to the flight crew of adherence to or departure from track to the required degree of accuracy at any point along that track; and
- b) has been authorized by the CAAB for the MNPS operations concerned.

Note.—*The prescribed minimum navigation performance specifications and the procedures governing their application are published in the Regional Supplementary Procedures (Doc 7030).*

2.5.2.7 For flights in defined portions of airspace where, based on Regional Air Navigation Agreement, a reduced vertical separation minimum (RVSM) of 300 m (1 000 ft) is applied between FL 290 and FL 410 inclusive:

- a) the aeroplane shall be provided with equipment which is capable of:
 - 1) indicating to the flight crew the flight level being flown;
 - 2) automatically maintaining a selected flight level;
 - 3) providing an alert to the flight crew when a deviation occurs from the selected flight level. The threshold for the alert shall not exceed ± 90 m (300 ft); and
 - 4) automatically reporting pressure-altitude;
- b) CAAB shall issue a specific approval for RVSM operations.

2.5.2.8 Prior to granting the RVSM specific approval required in accordance with 2.5.2.7 b), CAAB shall be satisfied that:

- a) the vertical navigation performance capability of the aeroplane satisfies the requirements specified in Appendix 2.2;
- b) the owner/operator has instituted appropriate procedures in respect of continued airworthiness (maintenance and repair) practices and programmes; and
- c) the owner/operator has instituted appropriate flight crew procedures for operations in RVSM airspace.

Note.—*An RVSM specific approval is valid globally on the understanding that any operating procedures specific to a given region will be stated in the operations manual or appropriate crew guidance.*

2.5.2.9 CAAB shall ensure that, in respect of those aeroplanes mentioned in 2.5.2.7, adequate provisions exist for:

- a) receiving the reports of height-keeping performance issued by the monitoring agencies established in accordance with ANO 11, 3.3.5.1; and

- b) taking immediate corrective action for individual aircraft, or aircraft type groups, identified in such reports as not complying with the height-keeping requirements for operation in airspace where RVSM is applied.

2.5.2.10 The State of Registry that has issued an RVSM specific approval to an owner/operator shall establish a requirement which ensures that a minimum of two aeroplanes of each aircraft type grouping of the owner/ operator have their height-keeping performance monitored, at least once every two years or within intervals of 1000 flight hours per aeroplane, whichever period is longer. If an owner/operator aircraft type grouping consists of a single aeroplane, monitoring of that aeroplane shall be accomplished within the specified period.

Note.— Monitoring data from any regional monitoring programme established in accordance with ANO 11, 3.3.5.2, may be used to satisfy the requirement.

2.5.2.11 CAAB shall establish provisions and procedures which ensure that appropriate action will be taken in respect of aircraft and owners/operators found to be operating in RVSM airspace without a valid RVSM specific approval.

Note 1.—*These provisions and procedures need to address both the situation where the aircraft in question was operating without a specific approval in the airspace of the State, and the situation where an owner/operator for which the State has regulatory oversight responsibility is found to be operating without the required specific approval in the airspace of another State.*

Note 2.—*Guidance material relating to the specific approval for operation in RVSM airspace is contained in the Manual on a 300 m (1000 ft) Vertical Separation Minimum Between FL 290 and FL 410 Inclusive (Doc 9574).*

2.5.2.12 The aeroplane shall be sufficiently provided with navigation equipment to ensure that, in the event of the failure of one item of equipment at any stage of the flight, the remaining equipment will enable the aeroplane to navigate in accordance with 2.5.2.1 and where applicable 2.5.2.2, 2.5.2.6 and 2.5.2.7.

Note 1.—*This requirement may be met by means other than the duplication of equipment.*

Note 2.—*Guidance material relating to aircraft equipment necessary for flight in airspace where a 300 m (1000 ft) RVSM is applied above FL 290 is contained in the Manual on a 300 m (1 000 ft) Vertical Separation Minimum Between FL 290 and FL 410 Inclusive (Doc 9574).*

2.5.2.13 On flights in which it is intended to land in instrument meteorological conditions, an aeroplane shall be provided with radio equipment capable of receiving signals providing guidance to a point from which a visual landing can be effected. This equipment shall be capable of providing such guidance for each aerodrome at which it is intended to land in instrument meteorological conditions and for any designated alternate aerodromes.

2.5.3 Surveillance equipment

2.5.3.1 An aeroplane shall be provided with surveillance equipment which will enable it to operate in accordance with the requirements of air traffic services.

2.5.3.2 For operations where surveillance equipment is required to meet an RSP specification for performance-based surveillance (PBS), an aeroplane shall, in addition to the requirements specified in 2.5.3.1:

- a) be provided with surveillance equipment which will enable it to operate in accordance with the prescribed RSP specification(s);
- b) have information relevant to the aeroplane RSP specification capabilities listed in the flight manual or other aeroplane documentation approved by the State of Design or CAAB; and
- c) where the aeroplane is operated in accordance with a MEL, have information relevant to the aeroplane RSP specification capabilities included in the MEL.

Note 1.— *Information on surveillance equipment is contained in the Aeronautical Surveillance Manual (Doc 9924).*

Note 2.— *Information on RSP specifications for performance-based surveillance is contained in the Performance-based Communication and Surveillance (PBCS) Manual (Doc 9869).*

2.5.3.3 CAAB shall establish criteria for operations where an RSP specification for PBS has been prescribed.

2.5.3.4 In establishing criteria for operations where an RSP specification for PBS has been prescribed, CAAB shall require that the operator/owner establish:

- a) normal and abnormal procedures, including contingency procedures;
- b) flight crew qualification and proficiency requirements, in accordance with appropriate RSP specifications;
- c) a training programme for relevant personnel consistent with the intended operations; and
- d) appropriate maintenance procedures to ensure continued airworthiness, in accordance with appropriate RSP specifications.

2.5.3.5 CAAB shall ensure that, in respect of those aeroplanes mentioned in 2.5.3.2, adequate provisions exist for:

- a) receiving the reports of observed surveillance performance issued by monitoring programmes established in accordance with ANO 11, Chapter 3, 3.3.5.2; and
- b) taking immediate corrective action for individual aircraft, aircraft types or operators, identified in such reports as not complying with the RSP specification(s).

CHAPTER 2.6 AEROPLANE CONTINUING AIRWORTHINESS

Note 1.—For the purpose of this chapter “aeroplane” includes: engines, propellers, components, accessories, instruments, equipment and apparatus including emergency equipment.

Note 2.—Airworthiness & Engineering Division of CAAB is encouraged to conduct a risk assessment when approving a maintenance programme not based on the type certificate holder’s maintenance recommendations.

2.6.1 Owner’s continuing airworthiness responsibilities

2.6.1.1 The owner of an aeroplane, or in the case where it is leased, the lessee, shall ensure that, in accordance with procedures acceptable to the CAAB:

- a) the aeroplane is maintained in an airworthy condition;
- b) the operational and emergency equipment necessary for an intended flight is serviceable; and
- c) the certificate of airworthiness along with airworthiness review certificate of the aeroplane remains valid.

2.6.1.2 The owner or the lessee shall not operate an aeroplane unless maintenance on the aeroplane, including any associated engine, propeller and part, is carried out:

- a) by an organization complying with CAAB ANO (AW) Part M and Part 145, as applicable, that is either approved by the State of Registry of the aeroplane or is approved by another Contracting State and is accepted by the State of Registry; or
- b) by a person or organization in accordance with procedures that are authorized by the State of Registry; and
- c) there is a maintenance release in relation to the maintenance carried out.

2.6.1.3 The owner or the lessee shall ensure that the maintenance of the aeroplane is performed in accordance with a maintenance programme approved by the CAAB.

2.6.2 Continuing airworthiness records

2.6.2.1 The owner of an aeroplane, or in the case where it is leased, the lessee, shall ensure that the following records are kept for the periods mentioned in 2.6.2.2:

- a) the total time in service (hours, calendar time and cycles, as appropriate) of the aeroplane and all life-limited components;
- b) the current status of compliance with all applicable mandatory continuing airworthiness information;
- c) appropriate details of modifications and repairs;
- d) the time in service (hours, calendar time and cycles, as appropriate) since the last overhaul of the aeroplane or its components subject to a mandatory overhaul life;
- e) the current status of the aeroplane's compliance with the maintenance programme; and
- f) the detailed maintenance records to show that all requirements for the signing of a maintenance release have been met.

2.6.2.2 The records in 2.6.2.1 a) to e) shall be kept for a minimum period of 90 days after the unit to which they refer has been permanently withdrawn from service and the records in 2.6.2.1 f) for a minimum period of one year after the signing of the maintenance release.

2.6.2.3 In the event of a temporary change of owner or lessee, the records shall be made available to the new owner or lessee. In the event of any permanent change of owner or lessee, the records shall be transferred to the new owner or lessee.

Note 1. — *Continuing airworthiness records or related documents, other than a valid certificate of airworthiness, need not be carried in the aeroplane during international flights.*

Note 2. — *In the context of 2.6.2.3, a judgement on what should be considered as a temporary change of owner or lessee will need to be made by the State of Registry in the light of the need to exercise control over the records, which will depend on access to them and the opportunity to update them.*

2.6.2.4 Records kept and transferred in accordance with 2.6.2 shall be maintained in a form and format that ensures readability, security and integrity of the records at all times.

Note 1. — *The form and format of the records may include, for example, paper records, film records, electronic records or any combination thereof.*

Note 2. — *Guidance regarding electronic aircraft continuing airworthiness records is included in the Airworthiness Manual (Doc 9760).*

2.6.3 Modifications and repairs

All modifications and repairs shall comply with the applicable airworthiness requirements laid down in ANO (AW) Part 21. Procedures shall be established to ensure that the substantiating data supporting compliance with the airworthiness requirements are retained.

2.6.4 Maintenance release

2.6.4.1 When maintenance is carried out by an approved maintenance organization, the maintenance release shall be issued by the approved maintenance organization in accordance with the provisions of ANO (AW) Part-M and Part 145 as applicable.

2.6.4.2 When maintenance is not carried out by an approved maintenance organization, the maintenance release shall be completed and signed by a person appropriately licensed in accordance with ANO 1 to certify that the maintenance work performed has been completed satisfactorily and in accordance with data and procedures acceptable to the CAAB.

2.6.4.3 When maintenance is not carried out by an approved maintenance organization, the maintenance release shall include the following:

- a) basic details of the maintenance performed;
- b) the date such maintenance was completed; and
- c) the identity of the authorized person or persons signing the release.

CHAPTER 2.7 AEROPLANE FLIGHT CREW**2.7.1 Composition of the flight crew**

The number and composition of the flight crew shall not be less than that specified in the flight manual or other documents associated with the certificate of airworthiness.

2.7.2 Qualifications

2.7.2.1 The pilot-in-command shall:

- a) ensure that each flight crew member holds a valid licence issued by the CAAB, or if issued by another Contracting State, rendered valid by the CAAB;
- b) ensure that flight crew members are properly rated; and
- c) be satisfied that flight crew members have maintained competency.

2.7.2.2 The pilot-in-command of an aeroplane equipped with an airborne collision avoidance system (ACAS II) shall ensure that each flight crew member has been appropriately trained to competency in the use of ACAS II equipment and the avoidance of collision.

Note 1.— *Procedures for the use of ACAS II equipment are specified in the Procedures for Air Navigation Services — Aircraft Operations (PANS-OPS, Doc 8168), Volume I — Flight Procedures. ACAS II Training Guidelines for Pilots are provided in PANS-OPS, Volume I, Attachment A to Part III, Section 3, Chapter 3.*

Note 2.— *Appropriate training, to the satisfaction of the CAAB, to competency in the use of ACAS II equipment and the avoidance of collisions may be evidenced, for example, by:*

- a) *possession of a type rating for an aeroplane equipped with ACAS II, where the operation and use of ACAS II are included in the training syllabus for the type rating; or*
- b) *possession of a document issued by a training organization or person approved by the State to conduct training for pilots in the use of ACAS II, indicating that the holder has been trained in accordance with the guidelines referred to in Note 1; or*
- c) *a comprehensive pre-flight briefing by a pilot who has been trained in the use of ACAS II in accordance with the guidelines referred to in Note 1.*

CHAPTER 2.8 MANUALS, LOGS AND RECORDS

Note.—*The following documents are associated with this ANO but are not included in this chapter: Maintenance airworthiness records — see 2.6.2.*

2.8.1 Flight manual

Note.—*The aeroplane flight manual contains the information specified in ANO (AW) Part 21.*

The aeroplane flight manual shall be updated by implementing changes made mandatory by the CAAB. Refer to ANO (AW) Part 21 for applicable requirements.

2.8.2 Journey log book

2.8.2.1 A journey log book shall be maintained for every aeroplane engaged in international air navigation in which shall be entered particulars of the aeroplane, its crew and each journey.

2.8.2.2 *The aeroplane journey log should contain the following items:*

- a) *aeroplane nationality and registration;*
- b) *date;*
- c) *crew member names and duty assignments;*
- d) *departure and arrival points and times; e) purpose of flight;*
- f) *observations regarding the flight; and g) signature of the pilot-in-command.*

2.8.3 Records of emergency and survival equipment carried

The owner of the aeroplane, or in the case where it is leased, the lessee, shall at all times have available for immediate communication to rescue coordination centres, lists containing information on the emergency and survival equipment carried on board the aeroplane engaged in international air navigation. The information shall include, as applicable, the number, colour and type of life rafts and pyrotechnics, details of emergency medical supplies, water supplies and the type and frequencies of the emergency portable radio equipment.

CHAPTER 2.9 SECURITY

2.9.1 Security of aircraft

The pilot-in-command shall be responsible for the security of the aircraft during its operation.

2.9.2 Reporting acts of unlawful interference

Following an act of unlawful interference, the pilot-in-command shall submit a report of such an act to CAAB and to the designated local authority.

Note.— *In the context of this chapter, the word “security” is used in the sense of prevention of acts of unlawful interference against civil aviation.*

APPENDIX 2.1 LIGHTS TO BE DISPLAYED BY AEROPLANES

(Section 2, Chapter 2.4, 2.4.8, refers)

1. TERMINOLOGY

When the following terms are used in this Appendix, they have the following meanings:

Angles of coverage.

- a) Angle of coverage A is formed by two intersecting vertical planes making angles of 70 degrees to the right and 70 degrees to the left respectively, looking aft along the longitudinal axis to a vertical plane passing through the longitudinal axis.
- b) Angle of coverage F is formed by two intersecting vertical planes making angles of 110 degrees to the right and 110 degrees to the left respectively, looking forward along the longitudinal axis to a vertical plane passing through the longitudinal axis.
- c) Angle of coverage L is formed by two intersecting vertical planes, one parallel to the longitudinal axis of the aeroplane, and the other 110 degrees to the left of the first, when looking forward along the longitudinal axis.
- d) Angle of coverage R is formed by two intersecting vertical planes, one parallel to the longitudinal axis of the aeroplane, and the other 110 degrees to the right of the first, when looking forward along the longitudinal axis.

Horizontal plane. The plane containing the longitudinal axis and perpendicular to the plane of symmetry of the aeroplane.

Longitudinal axis of the aeroplane. A selected axis parallel to the direction of flight at a normal cruising speed, and passing through the centre of gravity of the aeroplane.

Making way. An aeroplane on the surface of the water is “making way” when it is under way and has a velocity relative to the water.

Under command. An aeroplane on the surface of the water is “under command” when it is able to execute manoeuvres as required by the *International Regulations for Preventing Collisions at Sea* for the purpose of avoiding other vessels.

Under way. An aeroplane on the surface of the water is “under way” when it is not aground or moored to the ground or to any fixed object on the land or in the water.

Vertical planes. Planes perpendicular to the horizontal plane.

Visible. Visible on a dark night with a clear atmosphere.

2. NAVIGATION LIGHTS TO BE DISPLAYED IN THE AIR

Note.—The lights specified herein are intended to meet the requirements of ANO-2 for navigation lights.

As illustrated in Figure 1, the following unobstructed navigation lights shall be displayed:

- a) a red light projected above and below the horizontal plane through angle of coverage L;
- b) a green light projected above and below the horizontal plane through angle of coverage R;
- c) a white light projected above and below the horizontal plane rearward through angle of coverage A.

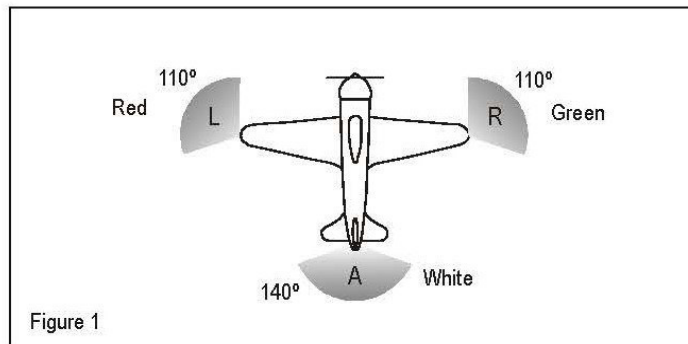

3. LIGHTS TO BE DISPLAYED ON THE WATER

3. LIGHTS TO BE DISPLAYED ON THE WATER

3.1 General

Note.— The lights specified herein are intended to meet the requirements of ANO-2 for lights to be displayed by aeroplanes on the water.

The *International Regulations for Preventing Collisions at Sea* require different lights to be displayed in each of the following circumstances:

- a) when under way;
- b) when towing another vessel or aeroplane;
- c) when being towed;
- d) when not under command and not making way;
- e) when making way but not under command;
- f) when at anchor;
- g) when aground.

The lights required by aeroplanes in each case are described below.

3.2 When under way

As illustrated in Figure 2, the following appearing as steady, unobstructed lights:

- a) a red light projected above and below the horizontal through angle of coverage L;
- b) a green light projected above and below the horizontal through angle of coverage R;
- c) a white light projected above and below the horizontal through angle of coverage A; and
- d) a white light projected through angle of coverage F.

The lights described in a), b), and c) should be visible at a distance of at least 3.7 km (2 NM). The light described in d) should be visible at a distance of 9.3 km (5 NM) when fitted to an aeroplane of 20 m or more in length or visible at a distance of 5.6 km (3 NM) when fitted to an aeroplane of less than 20 m in length.

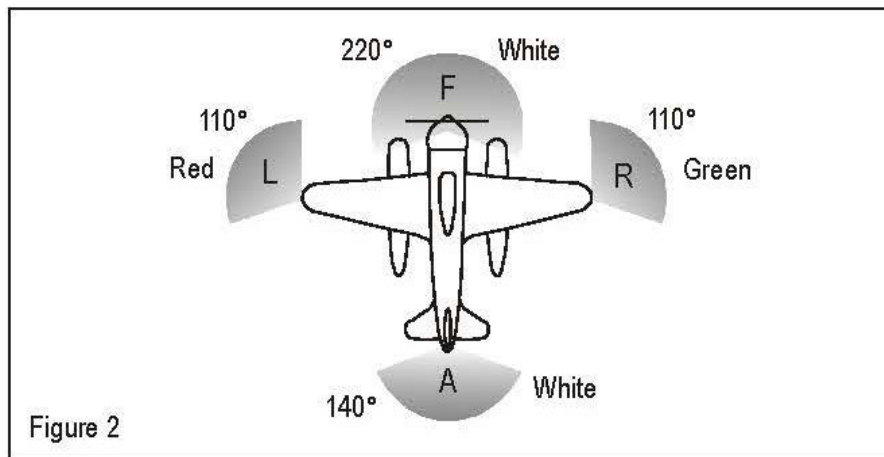

Figure 2

Figure 2

3.3 When towing another vessel or aeroplane

As illustrated in Figure 3, the following appearing as steady, unobstructed lights:

- the lights described in 3.2;
- a second light having the same characteristics as the light described in 3.2 d) and mounted in a vertical line at least 2 m above or below it; and
- a yellow light having otherwise the same characteristics as the light described in 3.2 c) and mounted in a vertical line at least 2 m above it.

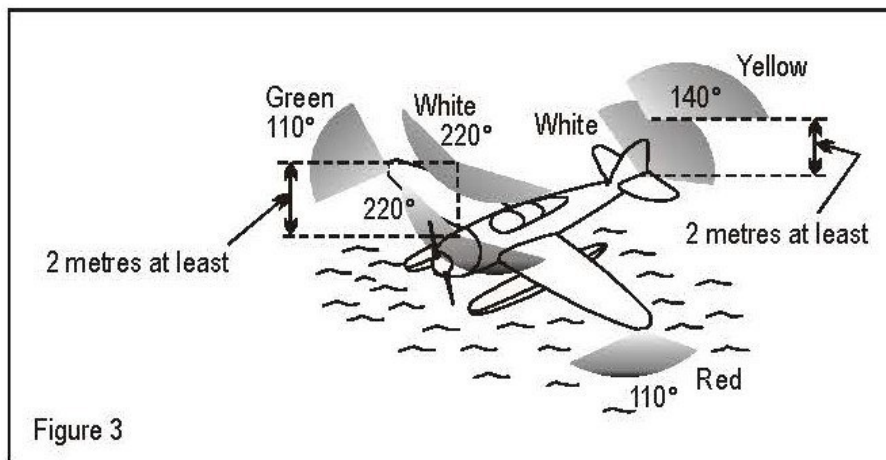

3.4 When being towed

The lights described in 3.2 a), b) and c) appearing as steady, unobstructed lights.

3.5 When not under command and not making way

As illustrated in Figure 4, two steady red lights placed where they can best be seen, one vertically over the other and not less than 1 m apart, and of such a character as to be visible all around the horizon at a distance of at least 3.7 km (2 NM).

3.6 When making way but not under command

As illustrated in Figure 5, the lights described in 3.5 plus the lights described in 3.2 a), b) and c).

Note.— *The display of lights prescribed in 3.5 and 3.6 is to be taken by other aircraft as signals that the aeroplane showing them is not under command and cannot therefore get out of the way. They are not signals of aeroplanes in distress and requiring assistance.*

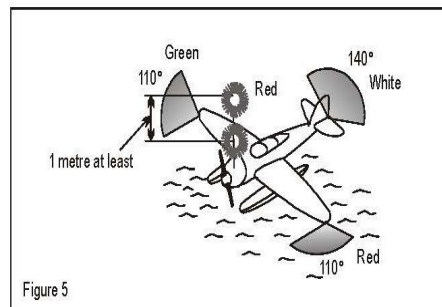
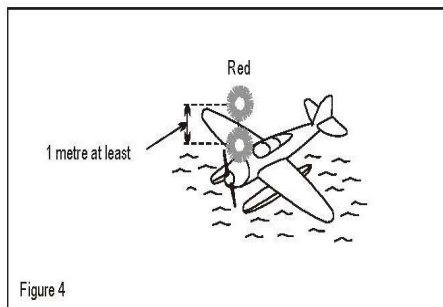

3.7 When at anchor

- a) If less than 50 m in length, where it can best be seen, a steady white light (Figure 6), visible all around the horizon at a distance of at least 3.7 km (2 NM).
- b) If 50 m or more in length, where they can best be seen, a steady white forward light and a steady white rear light (Figure 7) both visible all around the horizon at a distance of at least 5.6 km (3 NM).

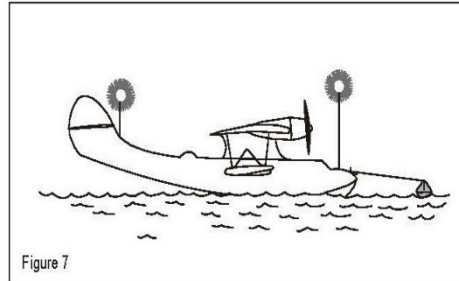
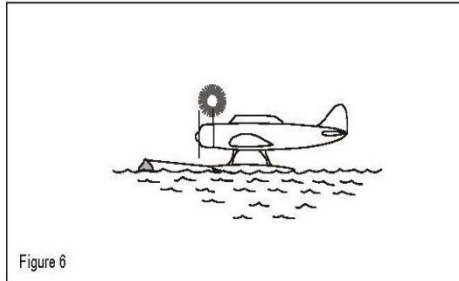

- c) If 50 m or more in span a steady white light on each side (Figures 8 and 9) to indicate the maximum span and visible, so far as practicable, all around the horizon at a distance of at least 1.9 km (1 NM).

3.8 When aground

The lights prescribed in 3.7 and in addition two steady red lights in vertical line, at least 1 m apart so placed as to be visible all around the horizon.

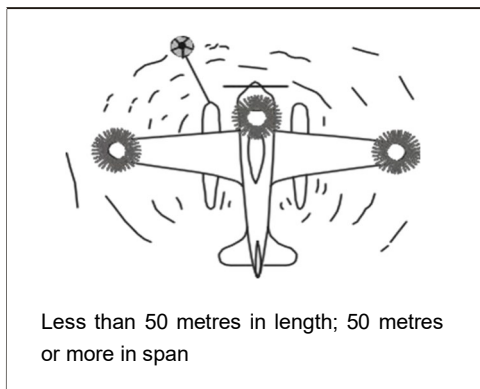

Figure 8

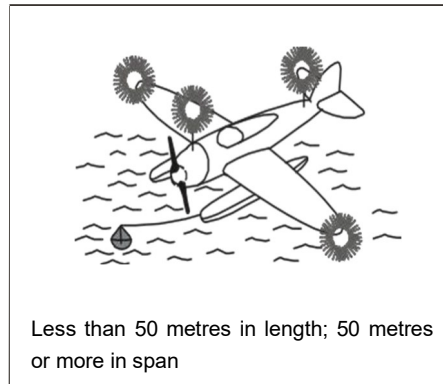

Figure 9

APPENDIX 2.2**ALTIMETRY SYSTEM PERFORMANCE REQUIREMENTS FOR OPERATIONS IN RVSM AIRSPACE** (*Section 2, Chapter 2.5, 2.5.2.8, refers*)

1. In respect of groups of aeroplanes that are nominally of identical design and build with respect to all details that could influence the accuracy of height-keeping performance, the height-keeping performance capability shall be such that the total vertical error (TVE) for the group of aeroplanes shall have a mean no greater than 25 m (80 ft) in magnitude and shall have a standard deviation no greater than $28 - 0.013z^2$ for $0 \leq z \leq 25$ when z is the magnitude of the mean TVE in metres, or $92 - 0.004z^2$ for $0 \leq z \leq 80$ where z is in feet. In addition, the components of TVE shall have the following characteristics:

- a) the mean altimetry system error (ASE) of the group shall not exceed 25 m (80 ft) in magnitude;
- b) the sum of the absolute value of the mean ASE and of three standard deviations of ASE shall not exceed 75 m (245 ft); and
- c) the differences between cleared flight level and the indicated pressure altitude actually flown shall be symmetric about a mean of 0 m, with a standard deviation no greater than 13.3 m (43.7 ft), and in addition, the decrease in the frequency of differences with increasing difference magnitude shall be at least exponential.

2. In respect of aeroplanes for which the characteristics of the airframe and altimetry system fit are unique and so cannot be classified as belonging to a group of aeroplanes encompassed by paragraph 1, the height-keeping performance capability shall be such that the components of the TVE of the aeroplane have the following characteristics:

- a) the ASE of the aeroplane shall not exceed 60 m (200 ft) in magnitude under all flight conditions; and
- b) the differences between the cleared flight level and the indicated pressure altitude actually flown shall be symmetric about a mean of 0 m, with a standard deviation no greater than 13.3 m (43.7 ft), and in addition, the decrease in the frequency of differences with increasing difference magnitude shall be at least exponential.

APPENDIX 2.3 FLIGHT RECORDERS

(Section 2, Chapter 2.4, 2.4.16, refers)

The material in this Appendix concerns flight recorders intended for installation in aeroplanes engaged in international air navigation. Crash-protected flight recorders comprise one or more of the following:

- a flight data recorder (FDR),
- a cockpit voice recorder (CVR),
- an airborne image recorder (AIR),
- a data link recorder (DLR).

When image or data link information is required to be recorded on a crash-protected flight recorder, it is permissible to record it on either the CVR or the FDR.

Lightweight flight recorders comprise one or more of the following:

- an aircraft data recording system (ADRS),
- a cockpit audio recording system (CARS),
- an airborne image recording system (AIRS),
- a data link recording system (DLRS).

When image or data link information is required to be recorded on a lightweight flight recorder, it is permissible to record it on either the CARS or the ADRS.

1. GENERAL REQUIREMENTS

1.1 Non-deployable flight recorder containers shall be painted a distinctive orange colour.

1.2 Non-deployable crash-protected flight recorder containers shall:

- a) carry reflective material to facilitate their location; and
- b) have securely attached an automatically activated underwater locating device operating at a frequency of 37.5 kilohertz (kHz). At the earliest practical date, but not later than 1 January 2018, this device shall operate for a minimum of 90 days.

1.3 Automatic deployable flight recorder containers shall:

- a) be painted a distinctive orange colour, however the surface visible from outside the aircraft may be of another colour;
- b) carry reflective material to facilitate their location; and
- c) have an integrated automatically activated ELT.

1.4 The flight recorder systems shall be installed so that:

- a) the probability of damage to the recordings is minimized;
- b) there is an aural or visual means for pre-flight checking that the flight recorder systems are operating properly; and
- c) if the flight recorder systems have an erasure device, the installation shall be designed to prevent operation of the device during flight time or crash impact; and
- d) aeroplanes for which the individual certificate of airworthiness is first issued on or after 1 January 2023, a flight crew-operated erase function shall be provided on the flight deck which, when activated, modifies the recording of a CVR and AIR so that it cannot be retrieved using normal replay or copying techniques. The installation shall be designed to prevent activation during flight. In addition, the probability of an inadvertent activation of an erase function during an accident shall also be minimized.

Note.— The erase function is intended to prevent access to CVR and AIR recordings by normal replay or copying means, but would not prevent accident investigation authorities access to such recordings by specialized replay or copying techniques.

1.5 The crash-protected flight recorders shall be installed so that they receive electrical power from a bus that provides the maximum reliability for operation of the flight recorders without jeopardizing service to essential or emergency loads.

1.6 The lightweight flight recorders shall be connected to a power source having the characteristics which ensure proper and reliable recording in the operational environment.

1.7 The flight recorder systems, when tested by methods approved by the appropriate certificating authority, shall be demonstrated to be suitable for the environmental extremes over which they are designed to operate.

1.8 Means shall be provided for an accurate time correlation between the recorder systems recordings.

1.9 The flight recorder system manufacturer shall provide the appropriate certificating authority with the following information in respect of the flight recorder systems:

- a) manufacturer's operating instructions, equipment limitations and installation procedures; b) parameter origin or source and equations which relate counts to units of measurement; c) manufacturer's test reports; and
- d) detailed information to ensure the continued serviceability of the flight recorder system.

1.10 The holder of the airworthiness approval for the installation design of the flight recorder system shall make available the relevant continuing airworthiness information to the operator of the aeroplane to be incorporated in the continuing airworthiness maintenance programme. This continuing airworthiness information shall cover in detail all the tasks required to ensure the continued serviceability of the flight recorder system.

Note 1.— The flight recorder system is composed of the flight recorder as well as any dedicated sensors, hardware and software that provide information required in this Appendix.

Note 2.— Conditions related to the continued serviceability of a flight recorder system are defined in section 6 of this appendix. The Manual on Flight Recorder System Maintenance (FRSM) (Doc 10104) provides guidance on maintenance tasks associated with flight recorder systems

2. FLIGHT DATA RECORDER (FDR) AND AIRCRAFT DATA RECORDING SYSTEM (ADRS)

2.1 Start and stop logic

The FDR or ADRS shall start to record prior to the aeroplane moving under its own power and record continuously until the termination of the flight when the aeroplane is no longer capable of moving under its own power.

2.2 Parameters to be recorded

2.2.1 The parameters that satisfy the requirements for FDRs are listed in Table A2.3-1. The number of parameters to be recorded shall depend on aeroplane complexity. The parameters without an asterisk (*) are mandatory parameters which shall be recorded regardless of aeroplane complexity. In addition, the parameters designated by an asterisk (*) shall be recorded if an information data source for the parameter is used by aeroplane systems or the flight crew to operate the aeroplane. However, other parameters may be substituted with due regard to the aeroplane type and the characteristics of the recording equipment.

2.2.2 If further FDR recording capacity is available, recording of the following additional information should be considered:

- a) operational information from electronic display systems, such as electronic flight instrument systems (EFIS), electronic centralized aircraft monitor (ECAM) and engine indication and crew alerting system (EICAS). Use the following order of priority:
 - 1) parameters selected by the flight crew relating to the desired flight path, e.g. barometric pressure setting, selected altitude, selected airspeed, decision height, and autoflight system engagement and mode indications if not recorded from another source;
 - 2) display system selection/status, e.g. SECTOR, PLAN, ROSE, NAV, WXR, COMPOSITE, COPY;
 - 3) warnings and alerts; and
 - 4) the identity of displayed pages for emergency procedures and checklists;
- b) retardation information including brake application for use in the investigation of landing overruns and rejected take-offs.

2.2.2.3 The parameters that satisfy the recommendations for flight path and speed as displayed to the pilot(s) are listed below. The parameters without an (*) are mandatory parameters which shall be recorded. In addition, the parameters designated by an (*) are to be recorded if an information source for the parameter is displayed to the pilot and is practicable to record:

- Pressure altitude
- Indicated airspeed or calibrated airspeed
- Heading (primary flight crew reference)
- Pitch attitude
- Roll attitude
- Engine thrust/power
- Landing gear status*
- Total or outside air temperature*
- Time*
- Navigation data*: Drift angle, wind speed, wind direction, latitude/longitude
- Radio altitude*

2.2.4 The parameters that satisfy the requirements for ADRS are the first 7 parameters listed in Table A2.3-3.

2.2.5 If further ADRS recording capacity is available, the recording of any parameters from 8 onwards defined in Table A 2.3-3 shall be considered.

2.3 Additional information

2.3.1 The measurement range, recording interval and accuracy of parameters on installed equipment shall be verified by methods approved by the appropriate certificating authority.

2.3.2 Documentation concerning parameter allocation, conversion equations, periodic calibration and other serviceability/maintenance information shall be maintained by the operator/owner. The documentation shall be sufficient to ensure that accident investigation authorities have the necessary information to read out the data in engineering units.

3. COCKPIT VOICE RECORDER (CVR) AND COCKPIT AUDIO RECORDING SYSTEM (CARS)

3.1 Start and stop logic

The CVR or CARS shall start to record prior to the aeroplane moving under its own power and record continuously until the termination of the flight when the aeroplane is no longer capable of moving under its own power. In addition, depending on the availability of electrical power, the CVR or CARS shall start to record as early as possible during the cockpit checks prior to engine start at the beginning of the flight until the cockpit checks immediately following engine shutdown at the end of the flight.

3.2 Signals to be recorded

3.2.1 The CVR shall record simultaneously on four separate channels, or more, at least the following:

- a) voice communication transmitted from or received in the aeroplane by radio;
- b) aural environment on the flight deck;
- c) voice communication of flight crew members on the flight deck using the aeroplane's interphone system, if installed;
- d) voice or audio signals identifying navigation or approach aids introduced in the headset or speaker; and
- e) digital communications with ATS, unless recorded by the FDR.

3.2.2 The preferred CVR audio allocation should be as follows:

- a) pilot-in-command audio panel;
- b) co-pilot audio panel;
- c) additional flight crew positions and time reference; and d) cockpit area microphone.

3.2.3 The CARS shall record simultaneously on two separate channels, or more, at least the following:

- a) voice communication transmitted from or received in the aeroplane by radio;
- b) aural environment on the flight deck; and
- c) voice communication of flight crew members on the flight deck using the aeroplane's interphone system, if installed.

3.2.4 The preferred CARS audio allocation should be as follows:

- a) voice communication; and
- b) aural environment on the flight deck.

4. AIRBORNE IMAGE RECORDER (AIR) AND AIRBORNE IMAGE RECORDING SYSTEM (AIRS)

4.1 Start and stop logic

The AIR or AIRS shall start to record prior to the aeroplane moving under its own power and record continuously until the termination of the flight when the aeroplane is no longer capable of moving under its own power. In addition, depending on the availability of electrical power, the AIR or AIRS shall start to record as early as possible during the cockpit checks prior to engine start at the beginning of the flight until the cockpit checks immediately following engine shutdown at the end of the flight.

4.2 Classes

4.2.1 A Class A AIR or AIRS captures the general cockpit area in order to provide data supplemental to conventional flight recorders.

***Note 1.**—To respect crew privacy, the cockpit area view may be designed as far as practical to exclude the head and shoulders of crew members whilst seated in their normal operating position.*

***Note 2.**— There are no provisions for Class A AIR or AIRS in this document.*

4.2.2 A Class B AIR or AIRS captures data link message displays.

4.2.3 A Class C AIR or AIRS captures instruments and control panels.

***Note.**— A Class C AIR or AIRS may be considered as a means for recording flight data where it is not practical or is prohibitively expensive to record on an FDR or an ADRS, or where an FDR is not required.*

5. DATA LINK RECORDER (DLR)

5.1 Applications to be recorded

5.1.1 Where the aircraft flight path is authorized or controlled through the use of data link messages, all data link messages, both uplinks (to the aircraft) and downlinks (from the aircraft), shall be recorded on the aircraft. As far as practicable, the time the messages were displayed to the flight crew and the time of the responses shall be recorded.

Note.— Sufficient information to derive the content of the data link communications message and the time the messages were displayed to the flight crew is needed to determine an accurate sequence of events on board the aircraft.

5.1.2 Messages applying to the applications listed in Table A2.3-2 shall be recorded. Applications without the asterisk (*) are mandatory applications which shall be recorded regardless of the system complexity. Applications with an (*) shall be recorded only as far as is practicable given the architecture of the system.

6. INSPECTIONS OF FLIGHT RECORDER SYSTEMS

6.1 Prior to the first flight of the day, the built-in test features for the flight recorders and flight data acquisition unit (FDAU), when installed, shall be monitored by manual and/or automatic checks.

6.2 FDR systems or ADRS, CVR systems or CARS, and AIR systems or AIRS shall have recording inspection intervals of one year; subject to the approval from the appropriate regulatory authority, this period may be extended to two years provided these systems have demonstrated a high integrity of serviceability and self-monitoring. DLR systems or DLRS shall have recording inspection intervals of two years; subject to the approval from the appropriate regulatory authority, this period may be extended to four years provided these systems have demonstrated high integrity of serviceability and self-monitoring.

6.3 Recording inspections shall be carried out as follows:

- a) an analysis of the recorded data from the flight recorders shall ensure that the recorder operates correctly for the nominal duration of the recording;
- b) the FDR or ADRS recording from a complete flight shall be examined in engineering units to evaluate the validity of all recorded parameters. Particular attention shall be given to parameters from sensors dedicated to the FDR or ADRS. Parameters taken from the aircraft's electrical bus system need not be checked if their serviceability can be detected by other aircraft systems;

- c) the readout facility shall have the necessary software to accurately convert the recorded values to engineering units and to determine the status of discrete signals;
- d) an examination of the recorded signal on the CVR or CARS shall be carried out by replay of the CVR or CARS recording. While installed in the aircraft, the CVR or CARS shall record test signals from each aircraft source and from relevant external sources to ensure that all required signals meet intelligibility standards;
- e) where practicable, during the examination, a sample of in-flight recordings of the CVR or CARS shall be examined for evidence that the intelligibility of the signal is acceptable;
- f) an examination of the recorded images on the AIR or AIRS shall be carried out by replay of the AIR or AIRS recording. While installed in the aircraft, the AIR or AIRS shall record test images from each aircraft source and from relevant external sources to ensure that all required images meet recording quality standards; and
- g) an examination of the recorded messages on the DLR or DLRS shall be carried out by replay of the DLR or DLRS recording.

6.4 A flight recorder system shall be considered unserviceable if there is a significant period of poor quality data, unintelligible signals, or if one or more of the mandatory parameters is not recorded correctly.

6.5 A report of the recording inspection shall be made available on request to regulatory authorities for monitoring purposes.

6.6 Calibration of the FDR system:

- a) for those parameters which have sensors dedicated only to the FDR and are not checked by other means, recalibration shall be carried out at least every five years or in accordance with the recommendations of the sensor manufacturer to determine any discrepancies in the engineering conversion routines for the mandatory parameters, and to ensure that parameters are being recorded within the calibration tolerances; and
- b) when the parameters of altitude and airspeed are provided by sensors that are dedicated to the FDR system, there shall be a recalibration performed as recommended by the sensor manufacturer, or at least every two years.

Table A2.3-1 Parameter characteristics for flight data recorders

Sl. No.	Parameter	Applicability	Measurement range	Maximum sampling and recording interval (seconds)	Accuracy limits (sensor input compared to FDR readout)	Recording resolution
1	Time (UTC when available, otherwise relative time count or GNSS time sync)		24 hours	4	±0.125%/h	1 s
2	Pressure altitude		-300 m (-1 000 ft) to maximum certificated altitude of aircraft +1 500 m (+5000 ft)	1	±30 m to ±200 m (±100 ft to ±700 ft)	1.5 m (5 ft)
3	Indicated airspeed or calibrated airspeed		95 km/h (50 kt) to max V _{so} (Note 1) V _{so} to 1.2 V _D (Note 2)	1	±5% ±3%	1 kt (0.5 kt recommended)
4	Heading (primary flight crew reference)	360°	1	±2°	0.5°	
5	Normal acceleration	-3 g to +6 g	0.125	±1% of maximum range excluding datum error of ±5%	0.004 g	
6	Pitch attitude	±75° or usable range whichever is greater	0.25	±2°	0.5°	
7	Roll attitude	±180°	0.25	±2°	0.5°	
8	Radio transmission keying	On-off (one discrete)	1			

Sl. No.	Parameter	Applicability	Measurement range	Maximum sampling and recording interval (seconds)	Accuracy limits (sensor input compared to FDR readout)	Recording resolution
9	Power on each engine (Note 3)	Full range	1 (per engine)	±2%	0.2% of full range or the resolution required to operate the aircraft	
10*	Trailing edge flap and cockpit control selection Parameter	Full range or each discrete position Applicability	2 Measurement range	±5% or as pilot's indicator Maximum sampling and recording Interval (seconds)	0.5% of full range or the resolution required to operate the aircraft Accuracy limits (sensor input compared to FDR readout)	Recording resolution
11*	Leading edge flap and cockpit control selection		Full range or each discrete position	2	±5% or as pilot's indicator	0.5% of full range or the resolution required to operate the aircraft
12*	Thrust reverser position		Stowed, in transit, and reverse	1 (per engine)		
13*	Ground spoiler/speed brake selection (selection and position)		Full range or each discrete position	1	±2% unless higher accuracy uniquely required	0.2% of full range
14	Outside air temperature		Sensor range	2	±2°C	0.3°C
15*	Autopilot/auto throttle/AFCS mode and engagement status		A suitable combination of discrete	1		

Sl. No.	Parameter	Applicability	Measurement range	Maximum sampling and recording interval (seconds)	Accuracy limits (sensor input compared to FDR readout)	Recording resolution
16	Longitudinal acceleration		±1 g	0.25	±0.015 g excluding a datum error of ±0.05 g	0.004 g
17	Lateral acceleration (Note 3)		±1 g	0.25	±0.015 g excluding a datum error of ±0.05 g	0.004 g
18	Pilot input and/or control surface position-primary controls (pitch, roll, yaw) (Notes 4 and 8)	Application for type certification submitted to a Contracting State before 1 January 2016	Full range	0.25	±2° unless higher accuracy uniquely required	0.2% of full range or as installed
19	Pitch trim position		Full range	1	±3% unless higher accuracy uniquely required	0.3% of full range or as installed
20*	Radio altitude		-6 m to 750 m (-20 ft to 2500 ft)	1	±0.6 m (±2 ft) or ±3% whichever is greater below 150 m (500 ft) and ±5% above 150 m (500 ft)	0.3 m (1 ft) below 150 m (500 ft) 0.3 m (1 ft) + 0.5% of full range Above 150 m (500 ft)
21*	Vertical beam deviation (ILS/ GNSS/ GLS glide path MLS elevation, IRNAV/IAN vertical deviation)		Signal range	1	±3%	0.3% of full range

Sl. No.	Parameter	Applicability	Measurement range	Maximum sampling and recording interval (seconds)	Accuracy limits (sensor input compared to FDR readout)	Recording resolution
22*	Horizontal beam deviation (ILS/GNSS/GLS localizer, MLS azimuth, IRNAV/IAN lateral deviation)		Signal range	1	±3%	0.3% of full range
23	Marker beacon passage		Discrete	1 (seconds)		
24	Master warning		Discrete	1		
25	Each NAV receiver frequency selection (Note 5)		Full range	4	As installed	
26*	DME 1 and 2 distance (includes distance to runway threshold (GLS) and distance to missed approach point (IRNAV/IAN) (Notes 5 and 6)		0–370 km (0–200 NM)	4	As installed	1 852 m (1 NM)
27	Air/ground status		Discrete	1		
28*	GPWS/TAWS/GCAS status (selection of terrain display mode including pop-up display status) and (terrain alerts, both cautions and warnings, and advisories) and (on/off switch position)		Discrete	1		
29*	Angle of attack		Full range	0.5	As installed	0.3% of full range
30*	Hydraulics, each system (low pressure)		Discrete	2		0.5% of full range

Sl. No.	Parameter	Applicability	Measurement range	Maximum sampling and recording interval (seconds)	Accuracy limits (sensor input compared to FDR readout)	Recording resolution
31*	Navigation data (latitude/longitude, ground speed and drift angle) (Note 7)		As installed	1	As installed	
32*	Landing gear and gear selector position		Discrete	4	As installed	
33*	Groundspeed		As installed	1	Data should be obtained from the most accurate system	1 kt
34	Brakes (left and right brake pressure, left and right brake pedal position)		(Maximum metered brake range, discrete or full range)	1	±5%	2% of full range
35*	Additional engine parameters (EPR, N1, indicated vibration level, N2, EGT, fuel flow, fuel cut-off lever position, N3 engine fuel metering valve position)	Engine fuel metering valve position: Application for type certification is submitted to a Contracting State on or after 1 January 2023	As installed	Each engine each second	As installed	2% of full range
36*	TCAS/ACAS (traffic alert and collision avoidance system)		Discrete(s)	1	As installed	
37*	Wind shear warning		Discrete	1	As installed	

Sl. No.	Parameter	Applicability	Measurement range	Maximum sampling and recording interval (seconds)	Accuracy limits (sensor input compared to FDR readout)	Recording resolution
38*	Selected barometric setting (pilot, co-pilot)		As installed	64	As installed	0.1 mb (0.01 in- Hg)
39*	Selected altitude (all pilot selectable modes of operation)		As installed	1	As installed	Sufficient to determine crew selection
40*	Selected speed (all pilot selectable modes of operation)		As installed	1	As installed	Sufficient to determine crew selection
41*	Selected Mach (all pilot selectable modes of operation)		As installed	1	As installed	Sufficient to determine crew selection
42*	Selected vertical speed (all pilot selectable modes of operation)		As installed	1	As installed	Sufficient to determine crew selection
43*	Selected heading (all pilot selectable modes of operation)		As installed	1	As installed	Sufficient to determine crew selection
44*	Selected flight path (all pilot selectable modes of operation) (course/DSTRK, path angle, final approach path (IRNAV/IAN))			1	As installed	As installed
45*	Selected decision height		As installed	64	As installed	Sufficient to determine crew selection

Sl. No.	Parameter	Applicability	Measurement range	Maximum sampling and recording interval (seconds)	Accuracy limits (sensor input compared to FDR readout)	Recording resolution
46*	EFIS display format (pilot, co-pilot)		Discrete(s)	4	As installed	
47*	Multi- function/ engine/alerts display format		Discrete(s)	4	As installed	
48*	AC electrical bus status		Discrete(s)	4	As installed	
49*	DC electrical bus status		Discrete(s)	4	As installed	
50*	Engine bleed valve position		Discrete(s)	4	As installed	
51*	APU bleed valve position		Discrete(s)	4	As installed	
52*	Computer failure		Discrete(s)	4	As installed	
53*	Engine thrust command		As installed	2	As installed	2% of full range
54*	Engine thrust target		As installed	4	As installed	2% of full range
55*	Computed centre of gravity		As installed	64	As installed	1% of full range
56*	Fuel quantity in CG trim tank		As installed	64	As installed	1% of full range
57*	Head-up display in use		As installed	4	As installed	
58*	Para-visual display on/off		As installed	1	As installed	
59*	Operational stall protection, stick shaker and pusher activation		As installed	1	As installed	
60*	Primary navigation system reference (GNSS, INS, VOR/ DME, MLS, Loran C, localizer glide slope)		As installed	4	As installed	

Sl. No.	Parameter	Applicability	Measurement range	Maximum sampling and recording interval (seconds)	Accuracy limits (sensor input compared to FDR readout)	Recording resolution
61*	Ice detection		As installed	4	As installed	
62*	Engine warning each engine vibration		As installed	1	As installed	
63*	Engine warning each engine over temperature		As installed	1	As installed	
64*	Engine warning each engine oil pressure low		As installed	1	As installed	
65*	Engine warning each engine over speed		As installed	1	As installed	
66*	Yaw trim surface position		Full range	2	±3% unless higher accuracy uniquely required	0.3% of full range
67*	Roll trim surface position		Full range	2	±3% unless higher accuracy uniquely required	0.3% of full range
68*	Yaw or sideslip angle		Full range	1	±5%	0.5°
69*	De-icing and/or anti-icing systems selection		Discrete(s)	4		
70*	Hydraulic pressure (each system)		Full range	2	±5%	100 psi
71*	Loss of cabin pressure		Discrete	1		
72*	Cockpit trim control input position, Pitch		Full range	1	±5%	0.2% of full range or as installed

Sl. No.	Parameter	Applicability	Measurement range	Maximum sampling and recording interval (seconds)	Accuracy limits (sensor input compared to FDR readout)	Recording resolution
73*	Cockpit trim control input position, Roll		Full range	1	±5%	0.2% of full range or as installed
74*	Cockpit trim control input position, Yaw		Full range	1	±5%	0.2% of full range or as installed
75	All cockpit flight control input forces (control wheel, control column, rudder pedal)		Full range (±311 N (±70 lbf), ±378 N (±85 lbf), ±734 N (±165 lbf))	1	±5%	0.2% of full range or as installed
76*	Event marker		Discrete	1		
77*	Date		365 days	64		
78*	Actual navigation performance or estimated position error or estimated position Uncertainty		As installed	4	As installed	
79*	Cabin pressure altitude	Application for type certification submitted to a Contracting State on or after 1 January 2023	As installed (0 ft to 40000 ft recommended)	1	As installed	100 ft
80*	Aeroplane computed weight	Application for type certification submitted to a Contracting State on or after 1 January 2023	As installed	64	As installed	1% of full range

Sl. No.	Parameter	Applicability	Measurement range	Maximum sampling and recording interval (seconds)	Accuracy limits (sensor input compared to FDR readout)	Recording resolution
80*	Aeroplane computed weight	Application for type certification submitted to a Contracting State on or after 1 January 2023	As installed	64	As installed	1% of full range
81*	Flight director command (left flight director pitch command, left flight director roll command, right flight director pitch command, right flight director roll command)	Application for type certification submitted to a Contracting State on or after 1 January 2023	Full range	1	$\pm 2^\circ$	0.5°
82*	Vertical speed	Application for type certification submitted to a Contracting State on or after 1 January 2023	As installed	0.25	As installed (32 ft/min recommended)	16 ft/min

Notes.—

1. *V_{so} stalling speed or minimum steady flight speed in the landing configuration is in Section “Abbreviations and Symbols”.*
2. *V_D design diving speed*
3. *Record sufficient inputs to determine power.*

4. *For aeroplanes with control systems in which movement of a control surface will back drive the pilot's control, "or" applies. For aeroplanes with control systems in which movement of a control surface will not back drive the pilot's control, "and" applies. In aeroplanes with split surfaces, a suitable combination of inputs is acceptable in lieu of recording each surface separately. In aeroplanes with independent pilot input on primary controls, each pilot input on primary controls needs to be recorded separately.*
5. *If signal available in digital form.*
6. *Recording of latitude and longitude from INS or other navigation system is a preferred alternative.*
7. *If signals readily available.*
8. *It is not intended that aeroplanes issued with an individual certificate of airworthiness before 1 January 2016 be modified to meet the measurement range, maximum sampling and recording intervals, accuracy limits or recording resolution guidance description detailed in this Appendix.*

Table A2.3-2. Description of applications for data link recorders

Item No.	Application type	Application description	Recording content
1	Data link initiation	This includes any applications used to log on to or initiate data link service. In FANS-1/A and ATN, these are ATS facilities notification (AFN) and context management (CM), respectively.	C
2	Controller-pilot communication	This includes any application used to exchange requests, clearances, instructions and reports between the flight crew and controllers on the ground. In FANS-1/A and ATN, this includes the CPDLC application. It also includes applications used for the exchange of oceanic (OCL) and departure clearances (DCL) as well as data link delivery of taxi clearances.	C
3	Addressed surveillance	This includes any surveillance application in which the ground sets up contracts for delivery of surveillance data. In FANS-1/A and ATN, this includes the automatic dependent surveillance — contract (ADS-C) application. Where parametric data are reported within the message they shall be recorded unless data from the same source are recorded on the FDR.	C
4	Flight information	This includes any service used for delivery of flight information to specific aircraft. This includes, for example, data link aviation weather report service (D-METAR), data link-automatic terminal service (D-ATIS), digital Notice to Airmen (D-NOTAM) and other textual data link services.	C
5	Aircraft broadcast surveillance	This includes elementary and enhanced surveillance systems, as well as automatic dependent surveillance — broadcast (ADS-B) output data. Where parametric data sent by the aeroplane are reported within the message they shall be recorded unless data from the same source are recorded on the FDR.	M*
6	Aeronautical operational control data	This includes any application transmitting or receiving data used for aeronautical operational control purposes (per the CAAB definition of operational control).	M*

Key:

C: Complete contents recorded.

M: Information that enables correlation to any associated records stored separately from the aeroplane.

*: Applications that are to be recorded only as far as is practicable given the architecture of the system.

Table A2.3-3. Parameter characteristics for aircraft data recording systems

Sl.No.	Parameter name	Minimum recording range	Maximum recording interval in seconds	Minimum recording accuracy	Minimum recording resolution	Remarks
1	Heading: a) Heading (Magnetic or True)	$\pm 180^\circ$	1	$\pm 2^\circ \pm 1\% + \text{drift of } 360^\circ/\text{h}$	0.5°	* Heading is preferred, if not available, yaw rate shall be recorded
	b) Yaw rate	$\pm 300^\circ/\text{s}$	0.25		$2^\circ/\text{s}$	
2	Pitch: a) Pitch attitude	$\pm 90^\circ$	0.25	$\pm 2^\circ$	0.5°	*Pitch altitude is preferred, if not available, pitch rate shall be recorded
	b) Pitch rate	$300^\circ/\text{s}$	0.25	$\pm 1\% + \text{drift of } 360^\circ/\text{h}$	$2^\circ/\text{s}$	
3	Roll: a) Roll attitude	$\pm 180^\circ$	0.25	$\pm 2^\circ$	0.5°	* If not available, roll rate shall be recorded
	b) Roll rate	$300^\circ/\text{s}$	0.25	$\pm 1\% + \text{drift of } 360^\circ/\text{h}$	$2^\circ/\text{s}$	
4	Positioning system: a) Time	24 hours	1	$\pm 0.5 \text{ s}$	0.1 s	UTC time preferred where available
	b) Latitude/longitude	Latitude: $\pm 90^\circ$ Longitude: $\pm 180^\circ$	2 (1 if available)	As installed (0.00015° recommended)	0.00005°	
	c) Altitude	-300 m (-1 000 ft) to maximum certificated altitude of aircraft + 1 500 m (5 000 ft)	2 (1 if available)	As installed ($\pm 15 \text{ m}$ ($\pm 50 \text{ ft}$) recommended)	1.5 m (5 ft)	
	d) Ground speed	0-1 000 kt	2 (1 if available)	As installed ($\pm 5 \text{ kt}$ recommended)	1 kt	

Sl.No.	Parameter name	Minimum recording range	Maximum recording interval in seconds	Minimum recording accuracy	Minimum recording resolution	Remarks
	e) Track	0-360°	2 (1 if available)	As installed (±2° recommended)	0.5°	
	f) Estimated error	Available range	2 (1 if available)	As installed	As installed	Shall be recorded if readily available
5	Normal acceleration	-3 g to +6 g (*)	0.25 (0.125 if available)	As installed (±0.09 g excluding a datum error of ±0.45 g recommended)	0.004 g	
6	Longitudinal acceleration	±1 g (*)	0.25 (0.125 if available)	As installed (±0.015 g excluding a datum error of ±0.05 g recommended)	0.004 g	
7	Lateral acceleration	±1 g (*)	0.25(0.125 if available)	As installed (±0.015 g excluding a datum error of ±0.05 g recommended)	0.004 g	
8	External static pressure (or pressure altitude)	34.4 mb (3.44 in-Hg) to 310.2 mb (31.02 in Hg) or available sensor range	1	As installed (±1 mb (0.1 in-Hg) or ±30 m (±100 ft) to ±210 m (±700 ft) recommended)	0.1 mb (0.01 in-Hg) or 1.5 m (5 ft)	
9	Outside air temperature (or total air temperature)	-50° to +90°C or available sensor range	2	As installed (±2°C recommended)	1°C	
10	Indicated air speed	As the installed pilot display measuring system or available sensor range	1	As installed (±3% recommended)	1 kt (0.5 kt recommended)	
11	Engine RPM	Full range including overspeed condition	Each engine each second	As installed	0.2% of full range	

Sl.No.	Parameter name	Minimum recording range	Maximum recording interval in seconds	Minimum recording accuracy	Minimum recording resolution	Remarks
12	Engine oil pressure	Full range	Each engine each second	As installed (5% of full range recommended)	2% of full range	
13	Engine oil temperature	Full range	Each engine each second	As installed (5% of full range recommended)	2% of full range	
14	Fuel flow or pressure	Full range	Each engine each second	As installed	2% of full range	
15	Manifold pressure	Full range	Each engine each second	As installed	0.2% of full range	
16	Engine thrust/power/torque parameters required to determine propulsive thrust/power*	Full range	Each engine each second	As installed	0.1% of full range	* Sufficient parameters e.g. EPR/N1 or torque/Np as appropriate to the particular engine shall be recorded to determine power in both normal and reverse thrust. A margin for possible overspeed should be provided.
17	Engine gas generator speed (Ng)	0-150%	Each engine each second	As installed	0.2% of full range	
18	Free power turbine speed (Nf)	0-150%	Each engine each second	As installed	0.2% of full range	

Sl.No.	Parameter name	Minimum recording range	Maximum recording interval in seconds	Minimum recording accuracy	Minimum recording resolution	Remarks
19	Coolant temperature	Full range	1	As installed ($\pm 5^{\circ}\text{C}$ recommended)	1 $^{\circ}\text{C}$	
20	Main voltage	Full range	Each engine each second	As installed	1 Volt	
21	Cylinder head temperature	Full range	Each cylinder each second	As installed	2% of full range	
22	Flaps position	Full range or each discrete position	2	As installed	0.5 $^{\circ}$	
23	Primary flight control surface position	Full range	0.25	As installed	0.2% of full range	
24	Fuel quantity	Full range	4	As installed	1% of full range	
25	Exhaust gas temperature	Full range	Each engine each second	As installed	2% of full range	
26	Emergency voltage	Full range	Each engine each second	As installed	1 Volt	
27	Trim surface position	Full range or each discrete position	1	As installed	0.3% of full range	
28	Landing gear position	Each discrete position*	Each gear every two seconds	As installed		*Where available, record up-and- locked and down-and- locked position
29	Novel/unique aircraft features	As required	As required	As required	As required	

APPENDIX 2.4 GENERAL AVIATION SPECIFIC APPROVALS
(Section 2, Chapter 2.1, 2.1.4, refers)

1. PURPOSE AND SCOPE

1.1 Specific approvals shall have a standardized format which contains the minimum information required in the specific approval template.

Note.— *When the operations to be conducted require a specific approval, a copy of the document(s) needs to be carried on board (see 2.4.2.2).*

2. SPECIFIC APPROVAL TEMPLATE

SPECIFIC APPROVAL		
ISSUING AUTHORITY and CONTACT DETAILS¹		
Issuing Authority ¹ _____		
Address _____		
Signature: _____	Date ² : _____	
Telephone: _____	Fax: _____	Email: _____
OWNER/OPERATOR		
Name ³ : _____		
Address: _____		
Telephone: _____	Fax: _____	Email: _____

Aircraft model ⁴ and registration marks:				
SPECIFIC APPROVAL	YES	NO	DESCRIPTION ⁵	REMARKS
Low visibility operations	<input type="checkbox"/>	<input type="checkbox"/>	CAT ⁶ : ____ RVR: __m DH: __ft RVR ⁷ : ____ m 8	
Approach and landing	<input type="checkbox"/>	<input type="checkbox"/>		
Take-off	<input type="checkbox"/>	<input type="checkbox"/>		
RVSM	<input type="checkbox"/>	<input type="checkbox"/>		
AR navigation specifications for PBN operations	<input type="checkbox"/>	<input type="checkbox"/>	9	
EFB	<input type="checkbox"/>	<input type="checkbox"/>	10	
Other ¹¹	<input type="checkbox"/>	<input type="checkbox"/>		

Notes.—

1. *Civil Aviation Authority name and contact details, including the telephone country code and email if available.*
2. *Issuance date of the specific approval (dd-mm-yyyy) and signature of the authority representative.*
3. *Owner or operator's name and address.*
4. *Insert the aeroplane make, model and series, or master series, if a series has been designated. The CAST/CAAB taxonomy is available at: <http://www.intlaviationstandards.org/>.*
5. *List in this column the most permissive criteria for each specific approval (with appropriate criteria).*
6. *Insert the applicable precision approach category (CAT II, III). Insert the minimum RVR in metres and decision height in feet. One line is used per listed approach category.*
7. *Insert the approved minimum take-off RVR in metres, or the equivalent horizontal visibility if RVR is not used. One line per approval may be used if different approvals are granted.*
8. *List the airborne capabilities (i.e. automatic landing, HUD, EVS, SVS, CVS) and associated operational credit(s) granted.*
9. *Performance-based navigation (PBN): one line is used for each PBN AR navigation specification approval (e.g. RNP AR APCH), with appropriate limitations listed in the "Description" column.*
10. *List the EFB functions used for the safe operation of aeroplanes and any applicable limitations*
11. *Other specific approvals or data can be entered here, using one line (or one multi-line block) per approval (e.g. specific approach operations approval).*

APPENDIX 2.5 ARTICLE 83 bis AGREEMENT SUMMARY
(Chapter 2.4, 2.4.18.4, refers)

Note.— Chapter 2.4, 2.4.18.1, requires a certified true copy of the agreement summary to be carried on board.

1. PURPOSE AND SCOPE

The Article 83 bis agreement summary should contain the information in the template at paragraph 2, in a standardized format.

2. ARTICLE 83 bis AGREEMENT SUMMARY

ARTICLE 83 bis AGREEMENT SUMMARY		
Title of the Agreement:		
CAAB:		Focal point:
State of the principal location of a general aviation operator:		Focal point:
Date of signature:	By CAAB ¹ :	
	By State of the principal location of a general aviation operator ¹ :	
Duration:	Start Date ¹ :	End Date (if applicable) ² :
Languages of the Agreement		
CAAB Registration No.:		
Umbrella Agreement (if any) with CAAB Registration number:		

Convention on International Civil Aviation	CAAB ANOs affected by the transfer of responsibility in respect of certain functions and duties to the State of the principal location of a general aviation operator			
Article 12: Rules of the air	ANO 2, all chapters	Yes <input type="checkbox"/>		
		No <input type="checkbox"/>		
Article 30 a): Aircraft radio equipment	Radio Station License	Yes <input type="checkbox"/>		
		No <input type="checkbox"/>		
Articles 30 b) And 32 a): Licenses of personnel	ANO 1, Chapters 1, 2, 3 and 6; and ANO 6-1, Radio Operator; or ANO 6-2, Part II (qualifications and/or flight crew member licensing); or ANO 6-3, Section II (composition of the flight crew (radio operator); or ANO 6-3, Section III (qualifications)	Yes <input type="checkbox"/>	ANO 6: paragraph ³	[Specify Part and and
		No <input type="checkbox"/>		
Article 31: Certificates of Airworthiness	ANO 6-1 or 6-3 Part I or Part III, Section II	Yes <input type="checkbox"/>	[Specify Part and chapters] ³	
		No <input type="checkbox"/>		
	ANO 6-2 or 6-3 Part II or Part III, Section III	Yes <input type="checkbox"/>	[Specify Part and chapters] ³	
		No <input type="checkbox"/>		
	ANO 8(ANO AW Part 21) Part II, Chapters 3 and 4	Yes <input type="checkbox"/>	[Specify chapters] ³	
		No <input type="checkbox"/>		

Aircraft affected by the transfer of responsibilities to the State of the principal location of a general aviation operator					
Aircraft make, model, series	Nationality and registration marks	Serial No.	AOC No. (Commercial air transport)	Dates of transfer of responsibilities	
				From ¹	To (if applicable) ²

Notes.—

1. dd/mm/yyyy.
2. dd/mm/yyyy or N/A if not applicable.
3. Square brackets indicate information that needs to be provided.

ATTACHMENT 2.A CARRIAGE AND USE OF OXYGEN*Supplementary to 2.2.3.8***INTRODUCTION**

The performance of crew members and the well-being of passengers during flights at such altitudes where a lack of oxygen might result in impairment of faculties are of major concern. Research conducted in altitude chambers or by exposure to mountain elevations indicates that human tolerance could be related to the altitude concerned and the exposure time. The subject is dealt with in detail in the *Manual of Civil Aviation Medicine* (Doc 8984). In light of the above and to further assist the pilot-in-command in providing the oxygen supply intended by 2.2.3.8 of this ANO, the following guidelines, which take into account the requirements already established in ANO 6, Part I, are considered relevant.

1. OXYGEN SUPPLY

1.1 A flight to be operated at altitudes at which the atmospheric pressure in personnel compartments will be less than 700 hPa should not be commenced unless sufficient stored breathing oxygen is carried to supply:

- a) all crew members and at least 10 per cent of the passengers for any period in excess of 30 minutes that the pressure in compartments occupied by them will be between 700 hPa and 620 hPa; and
- b) all crew members and passengers for any period that the atmospheric pressure in compartments occupied by them will be less than 620 hPa.

1.2 A flight to be operated with a pressurized aeroplane should not be commenced unless a sufficient quantity of stored breathing oxygen is carried to supply all crew members and passengers, as is appropriate to the circumstances of the flight being undertaken, in the event of loss of pressurization, for any period that the atmospheric pressure in any compartment occupied by them would be less than 700 hPa. In addition, when an aeroplane is operated at flight altitudes at which the atmospheric pressure is less than 376 hPa, or which, if operated at flight altitudes at which the atmospheric pressure is more than 376 hPa and cannot descend safely within four minutes to a flight altitude at which the atmospheric pressure is equal to 620 hPa, there shall be no less than a 10-minute supply for the occupants of the passenger compartment.

2. USE OF OXYGEN

2.1 All flight crew members, when engaged in performing duties essential to the safe operation of an aeroplane in flight, should use breathing oxygen continuously whenever the circumstances prevail for which its supply has been indicated to be necessary in 1.1 or 1.2.

2.2 All flight crew members of pressurized aeroplanes operating above an altitude where the atmospheric pressure is less than 376 hPa should have available at the flight duty station a quick donning type of mask which will readily supply oxygen upon demand.

Note.— Approximate altitudes in the Standard Atmosphere corresponding to the values of absolute pressure used in the text are as follows:

<i>Absolute pressure</i>	<i>Metres</i>	<i>Feet</i>
<i>700 hPa</i>	<i>3 000</i>	<i>10 000</i>
<i>620 hPa</i>	<i>4 000</i>	<i>13 000</i>
<i>376 hPa</i>	<i>7 600</i>	<i>25 000</i>

ATTACHMENT 2.B**GUIDE TO CURRENT FLIGHT RECORDER PROVISIONS***Supplementary to Chapter 2, 2.4.16***INTRODUCTION**

Since 1973, and the inclusion in ANO 6 of SARPs for the carriage of flight recorders, new and revised requirements were introduced concerning flight recorders. These amendments include an update of the provisions pertaining to flight recorders, recording of digital communications, FDR requirements for new aircraft, revised parameter listings, and two-hour duration CVRs. Through the years, the applicability date and the carriage of flight recorders to be installed, as defined by the SARPs, were complex.

The tables below summarize the current flight recorders carriage requirements.

Table A2.C-1. SARPs for the recording of flight parameters

	Maximum certificated take-off mass (MCTOM)
	5 700 kg and below
Date	All turbine-engined aeroplanes with more than five passengers – first certificate of airworthiness
2016 <input type="checkbox"/>	2.4.16.1.1.1

Table A2.C-2 CVR/CARS installation SARPs

	Maximum certificated take-off mass (MCTOM)
	5 700 kg and below
Date	All turbine-engined aeroplanes with more than five passengers required to be operated by more than one pilot – first certificate of airworthiness
2016 <input type="checkbox"/>	2.4.16.2.1

ANO 6-2**SECTION 3 LARGE AND TURBOJET AEROPLANES****CHAPTER 3.1 APPLICABILITY**

3.1.1 The following operations shall be subject to the provisions of Section 2, and those of Section 3:

International general aviation operations with:

- a) aeroplanes with a maximum certificated take-off mass exceeding 5700 kg; or
- b) aeroplanes equipped with one or more turbojet engines.

3.1.2 *An operation involving an aeroplane with a seating configuration of more than 9 passenger seats should be conducted in accordance with Section 3.*

Note.— *The applicability of 3.1 does not preclude a general aviation operator from satisfying the requirements of Section 3 where it may be to the operator's advantage.*

CHAPTER 3.2 CORPORATE AVIATION OPERATIONS

3.2.1 *A corporate aviation operation involving three or more aircraft that are operated by pilots employed for the purpose of flying the aircraft should be conducted in accordance with Section 3.*

Note.— *The term “aircraft” is used to indicate that a corporate aviation operation using a mix of aeroplanes and helicopters is subject to this provision as long as at least one aeroplane is involved.*

CHAPTER 3.3 GENERAL**3.3.1 Compliance with laws, regulations and procedures**

3.3.1.1 The operator shall ensure that all employees know that they must comply with the laws, regulations and procedures of those States in which operations are conducted.

Note.—Information for pilots on flight procedure parameters and operational procedures is contained in PANS-OPS (Doc 8168), Volume I. Criteria for the construction of visual and instrument flight procedures are contained in PANS-OPS (Doc 8168), Volume II. Obstacle clearance criteria and procedures used in certain States may differ from PANS-OPS, and knowledge of these differences is important for safety reasons.

3.3.1.2 The operator shall ensure that all pilots are familiar with the laws, regulations and procedures, pertinent to the performance of their duties, prescribed for the areas to be traversed, the aerodromes to be used and the air navigation facilities relating thereto. The operator shall ensure that other members of the flight crew are familiar with such of these laws, regulations and procedures as are pertinent to the performance of their respective duties in the operation of the aeroplane.

3.3.1.3 The pilot-in-command is responsible for operational control. The operator shall describe the operational control system in the operations manual and identify the roles and responsibilities of those involved with the system.

Note.— The rights and obligations of a State in respect to the operation of aeroplanes registered in that State are not affected by this provision.

3.3.1.4 The operator shall ensure that the pilot-in-command has available on board the aeroplane all the essential information concerning the search and rescue services in the area over which the aeroplane will be flown.

Note.— This information may be made available to the pilot by means of the operations manual or such other means as is considered appropriate.

3.3.1.5 The operator shall ensure that flight crew members demonstrate the ability to speak and understand the language used for aeronautical radiotelephony communications as specified in ANO-1.

3.3.2 Safety management

Note.— ANO-19 includes safety management provisions for international general aviation operators of large or turbojet aeroplanes.

3.3.2.1 CAAB shall not allow the use of recordings or transcripts of CVR, CARS, Class A AIR and Class A AIRS for purposes other than the investigation of an accident or incident as per Aircraft Accident Investigation Order (AAIO), except where the recordings or transcripts are:

- a) related to a safety-related event identified in the context of a safety management system; are restricted to the relevant portions of a de-identified transcript of the recording; and are subject to the protections accorded by ANO-19;
- b) sought for use in criminal proceedings not related to an event involving an accident or incident investigation and are subject to the protections accorded by ANO-19; or
- c) used for inspections of flight recorder systems as provided in Section 7 of Appendix 2.3.

Note.—Provisions on the protection of safety data, safety information and related sources are contained in Appendix 2 to the ANO-19. When an investigation under Aircraft is instituted, investigation records are subject to the protections accorded by Aircraft Accident Investigation Order (AAIO).

3.3.2.2 CAAB shall not allow the use of recordings or transcripts of FDR, ADRS, Class B and C AIR, and Class B and C AIRS for purposes other than the investigation of an accident or incident as per ANO-13, except where the recordings or transcripts are subject to the protections accorded by ANO-19 and are:

- a) used by the operator for airworthiness or maintenance purposes;
- b) sought for use in proceedings not related to an event involving an accident or incident investigation;
- c) de-identified; or
- d) disclosed under secure procedures.

Note.— Provisions on the protection of safety data, safety information and related sources are contained in Appendix 2 to the ANO-19.

CHAPTER 3.4 FLIGHT OPERATIONS**3.4.1 Operating facilities**

3.4.1.1 The operator shall ensure that a flight will not be commenced unless it has been ascertained by every reasonable means available that the ground and/or water facilities including communication facilities and navigation aids available and directly required on such flight, for the safe operation of the aeroplane, are adequate for the type of operation under which the flight is to be conducted.

Note.—“Reasonable means” in this Standard is intended to denote the use, at the point of departure, of information available to the operator either through official information published by the aeronautical information services or readily obtainable from other sources.

3.4.1.2 The operator, in making a decision on the adequacy of facilities and services available at an aerodrome of intended operation, shall assess the level of safety risk associated with the aircraft type and nature of the operation, in relation to the availability of rescue and firefighting services (RFFS).

3.4.2 Operational management**3.4.2.1 Operator notification**

3.4.2.1.1 If the operator has an operating base in a State other than the State of Registry, the operator shall notify the State in which the operating base is located.

3.4.2.1.2 Upon notification in accordance with 3.4.2.1.1, safety and security oversight shall be coordinated between the State in which the operating base is located and the State of Registry.

3.4.2.2 Operations manual

3.4.2.2.1 The operator shall provide, for the use and guidance of personnel concerned, an operations manual containing all the instructions and information necessary for operations personnel to perform their duties. The operations manual shall be amended or revised as is necessary to ensure that the information contained therein is kept up to date. All such amendments or revisions shall be issued to all personnel that are required to use this manual.

Note 1.— CAAB may reference accepted and recognized industry codes of practice as the basis for the development of an operations manual.

Note 2.— Attachment 3.A contains guidance on the organization and content of an operations manual.

3.4.2.3 Operating instructions — general

3.4.2.3.1 The operator shall ensure that all operations personnel are properly instructed in their particular duties and responsibilities and the relationship of such duties to the operation as a whole.

3.4.2.3.2 The operator should issue operating instructions and provide information on aeroplane climb performance with all engines operating to enable the pilot-in-command to determine the climb gradient that can be achieved during the departure phase for the existing take-off conditions and intended take-off technique. This information should be included in the operations manual.

3.4.2.4 In-flight simulation of emergency situations

3.4.2.4.1. The operator shall ensure that when passengers are being carried, no emergency or abnormal situations shall be simulated.

3.4.2.5 Checklists

3.4.2.5.1 Checklists shall be used by flight crews prior to, during and after all phases of operations, and in emergencies, to ensure compliance with the operating procedures contained in the aircraft operating manual and the aeroplane flight manual or other documents associated with the certificate of airworthiness and otherwise in the operations manual. The design and utilization of checklists shall observe Human Factors principles.

Note.— Guidance material on the application of Human Factors principles can be found in the Human Factors Training Manual (Doc 9683).

3.4.2.6 Minimum flight altitudes

3.4.2.6.1 The operator shall specify, for flights which are to be conducted in accordance with the instrument flight rules, the method of establishing terrain clearance altitudes.

3.4.2.7 Aerodrome operating minima

3.4.2.7.1 The operator shall establish aerodrome operating minima, in accordance with criteria specified by the CAAB, for each aerodrome to be used in operations. When establishing aerodrome operating minima, any conditions that may be prescribed in the list of specific approvals shall be observed. Such minima shall not be lower than any that may be established for such aerodromes by the State of the Aerodrome, except when specifically approved by that State.

Note.— This provision does not require the State of the Aerodrome to establish aerodrome operating minima.

3.4.2.8 Fatigue management programme

3.4.2.8.1 The operator shall establish and implement a fatigue management programme that ensures that all operator personnel involved in the operation and maintenance of aircraft do not carry out their duties when fatigued. The programme shall address flight and duty times and be included in the operations manual.

Note.— Guidance on fatigue management programmes can be found in the Fatigue Management Manual for General Aviation (Doc 10033).

3.4.2.9 Passengers

3.4.2.9.1 The operator shall ensure that passengers are made familiar with the location and use of:

- a) seat belts;
- b) emergency exits;
- c) life jackets, if the carriage of life jackets is prescribed;
- d) oxygen dispensing equipment, if the provision of oxygen for the use of passengers is prescribed; and
- e) other emergency equipment provided for individual use, including passenger emergency briefing cards.

3.4.2.9.2 The operator shall ensure that all persons on board are aware of the location and general manner of use of the principal emergency equipment carried for collective use.

3.4.2.9.3 The operator shall ensure that in an emergency during flight, passengers are instructed in such emergency action as may be appropriate to the circumstances.

3.4.2.9.4 The operator shall ensure that during take-off and landing and whenever considered necessary, by reason of turbulence or any emergency occurring during flight, all passengers on board an aeroplane are secured in their seats by means of the seat belts or harnesses provided.

3.4.3 Flight preparation

3.4.3.1 The operator shall develop procedures to ensure that a flight is not commenced unless:

- a) the aeroplane is airworthy, duly registered and that appropriate certificates with respect thereto are aboard the aeroplane;

- b) the instruments and equipment installed in the aeroplane are appropriate, taking into account the expected flight conditions;
- c) any necessary maintenance has been performed in accordance with Chapter 3.8;
- d) the mass of the aeroplane and centre of gravity location are such that the flight can be conducted safely, taking into account the flight conditions expected;
- e) any load carried is properly distributed and safely secured; and
- f) the aeroplane operating limitations, contained in the flight manual, or its equivalent, will not be exceeded.

3.4.3.2 The operator shall make available sufficient information on climb performance with all engines operating to enable determination of the climb gradient that can be achieved during the departure phase for the existing take-off conditions and intended take-off technique.

3.4.3.3 Operational flight planning

3.4.3.3.1 The operator should specify flight planning procedures to provide for the safe conduct of the flight based on considerations of aeroplane performance, other operating limitations and relevant expected conditions on the route to be followed and at the aerodromes concerned. These procedures shall be included in the operations manual.

Note 1.— The requirements for flight plans are contained in ANO 2 — Rules of the Air and Procedures for Air Navigation Services — Air Traffic Management (PANS-ATM, Doc 4444).

3.4.3.4 Alternate aerodromes

3.4.3.4.1 Take-off alternate aerodrome

3.4.3.4.1.1 A take-off alternate aerodrome shall be selected and specified in the flight plan if either the meteorological conditions at the aerodrome of departure are below the applicable aerodrome landing minima for that operation or if it would not be possible to return to the aerodrome of departure for other reasons.

3.4.3.4.1.2 The take-off alternate aerodrome shall be located within the following flight time from the aerodrome of departure:

- a) for aeroplanes with two engines, one hour of flight time at a one-engine-inoperative cruising speed, determined from the aircraft operating manual, calculated in ISA and still-air conditions using the actual take-off mass; or

- b) for aeroplanes with three or more engines two hours of flight time at an all engines operating cruising speed, determined from the aircraft operating manual, calculated in ISA and still-air conditions using the actual take-off mass.

3.4.3.4.1.3 For an aerodrome to be selected as a take-off alternate the available information shall indicate that, at the estimated time of use, the conditions will be at or above the applicable aerodrome operating minima for that operation.

3.4.3.5 Fuel requirements

3.4.3.5.1 An aeroplane shall carry a sufficient amount of usable fuel to complete the planned flight safely and to allow for deviations from the planned operation.

3.4.3.5.2 The amount of usable fuel to be carried shall, as a minimum, be based on:

- a) fuel consumption data:
 - 1) provided by the aeroplane manufacturer; or
 - 2) if available, current aeroplane-specific data derived from a fuel consumption monitoring system; and
- b) the operating conditions for the planned flight including:
 - 1) anticipated aeroplane mass;
 - 2) Notices to Airmen;
 - 3) current meteorological reports or a combination of current reports and forecasts;
 - 4) air traffic services procedures, restrictions and anticipated delays; and
 - 5) the effects of deferred maintenance items and/or configuration deviations.

Note.—Where no specific fuel consumption data exist for the precise conditions of the flight, the aircraft may be operated in accordance with estimated fuel consumption data.

3.4.3.5.3 The pre-flight calculation of usable fuel required shall include:

- a) *taxi fuel*, which shall be the amount of fuel expected to be consumed before take-off taking into account local conditions at the departure aerodrome and auxiliary power unit (APU) fuel consumption;

- b) *trip fuel*, which shall be the amount of fuel required to enable the aeroplane to fly from take-off until landing at the destination aerodrome taking into account the operating conditions of 3.4.3.5.2 b);
- c) *contingency fuel*, which shall be the amount of fuel required to compensate for unforeseen factors. It shall be not less than five per cent of the planned trip fuel;

Note.—*Unforeseen factors are those which could have an influence on the fuel consumption to the destination aerodrome, such as deviations of an individual aeroplane from the expected fuel consumption data, deviations from forecast meteorological conditions, extended delays and deviations from planned routings and/or cruising levels.*

- d) *destination alternate fuel*, which shall be:
 - 1) where a destination alternate aerodrome is required, the amount of fuel required to enable the aeroplane to:
 - i) perform a missed approach at the destination aerodrome;
 - ii) climb to the expected cruising altitude;
 - iii) fly the expected routing;
 - iv) descend to the point where the expected approach is initiated; and
 - v) conduct the approach and landing at the destination alternate aerodrome; or
 - 2) where a flight is operated without a destination alternate aerodrome, the amount of fuel required to enable the aeroplane to fly for 15 minutes at holding speed at 450 m (1 500 ft) above destination aerodrome elevation in standard conditions; or
 - 3) where the aerodrome of intended landing is an isolated aerodrome:
 - i) for a reciprocating engine aeroplane, the amount of fuel required to fly for 45 minutes plus 15 per cent of the flight time planned to be spent at cruising level, including final reserve fuel, or two hours, whichever is less; or
 - ii) for a turbine-engined aeroplane, the amount of fuel required to fly for two hours at normal cruise consumption above the destination aerodrome, including final reserve fuel;

- e) *final reserve fuel*, which shall be the amount of fuel on arrival at the destination alternate aerodrome, or the destination aerodrome when no destination alternate aerodrome is required:
- 1) for a reciprocating engine aeroplane, the amount of fuel required to fly for 45 minutes; or
 - 2) for a turbine-engined aeroplane, the amount of fuel required to fly for 30 minutes at holding speed at 450 m (1500 ft) above aerodrome elevation in standard conditions;
- f) *additional fuel*, which shall be the supplementary amount of fuel required to enable the aircraft to descend as necessary and proceed to land at an alternate aerodrome in the event of engine failure or loss of pressurization based on the assumption that such a failure occurs at the most critical point along the route;
- g) *discretionary fuel*, which shall be the extra amount of fuel to be carried at the discretion of the pilot-in-command.

Note: Operators may determine one final reserve fuel value for each aeroplane type and variant in their fleet rounded up to an easily recalled figure.

3.4.3.5.4 Operators should determine one final reserve fuel value for each aeroplane type and variant in their fleet rounded up to an easily recalled figure.

3.4.3.5.5 The use of fuel after flight commencement for purposes other than originally intended during pre-flight planning shall require a re-analysis and, if applicable, adjustment of the planned operation.

Note.— Nothing in 3.4.3.5 precludes the in-flight amendment of a flight plan to re-plan that flight to another aerodrome, provided that the requirements of 3.4.3.5 can be complied with from the point where the flight is re-planned.

3.4.3.6 In-flight fuel management

3.4.3.6.1 The operator shall establish policies and procedures to ensure that in-flight fuel checks and fuel management are performed.

3.4.3.6.2 The pilot-in-command shall continually ensure that the amount of usable fuel remaining on board is not less than the fuel required to proceed to an aerodrome where a safe landing can be made with the planned final reserve fuel remaining upon landing.

Note.— The protection of final reserve fuel is intended to ensure a safe landing at any aerodrome when unforeseen occurrences may not permit safe completion of an operation as originally planned. Guidance on flight planning including the circumstances that may require re-analysis, adjustment and/or re-planning of the planned operation before take-off or en- route, is contained in the Flight Planning and Fuel Management (FPFM) Manual (Doc 9976).

3.4.3.6.3 The pilot-in-command shall request delay information from ATC when unanticipated circumstances may result in landing at the destination aerodrome with less than the final reserve fuel plus any fuel required to proceed to an alternate aerodrome or the fuel required to operate to an isolated aerodrome.

3.4.3.6.4 The pilot-in-command shall advise ATC of a minimum fuel state by declaring MINIMUM FUEL when, having committed to land at a specific aerodrome, the pilot calculates that any change to the existing clearance to that aerodrome may result in landing with less than the planned final reserve fuel.

Note.— The declaration of MINIMUM FUEL informs ATC that all planned aerodrome options have been reduced to a specific aerodrome of intended landing and any change to the existing clearance may result in landing with less than the planned final reserve fuel. This is not an emergency situation but an indication that an emergency situation is possible should any additional delay occur.

3.4.3.6.5 The pilot-in-command shall declare a situation of fuel emergency by broadcasting MAYDAY MAYDAY MAYDAY FUEL when the calculated usable fuel estimated to be available upon landing at the nearest aerodrome where a safe landing can be made is less than the planned final reserve fuel.

Note 1.— The planned final reserve fuel refers to the value calculated in 3.4.3.5.3 e) and is the minimum amount of fuel required upon landing at any aerodrome.

Note 2.— The words “MAYDAY FUEL” describe the nature of the distress conditions as required in ANO 10, Volume II, 5.3.2.1.1, b) 3).

3.4.3.7 Additional requirements for operations beyond 60 minutes to an en-route alternate aerodrome

3.4.7.1 When conducting operations beyond 60 minutes from a point on a route to an en- route alternate aerodrome operators should ensure that:

- a) en-route alternate aerodromes are identified; and
- b) the pilot-in-command has access to current information on the identified en-route alternate aerodromes, including operational status and meteorological conditions.

3.4.3.8 Refuelling with passengers on board

3.4.3.8.1 An aeroplane shall not be refueled when passengers are embarking, on board or disembarking unless it is properly attended by qualified personnel ready to initiate and direct an evacuation of the aeroplane by the most practical and expeditious means available.

3.4.3.8.2 When refuelling with passengers embarking, on board or disembarking, two-way communication shall be maintained by the aeroplane's intercommunication system or other suitable means between the ground crew supervising the refuelling and the qualified personnel on board the aeroplane.

Note 1.— *The provisions of 3.4.3.5.1 do not necessarily require the deployment of integral aeroplane stairs or the opening of emergency exits as a prerequisite to refuelling.*

Note 2.— *Provisions concerning aircraft refuelling are contained in ANO-14, Volume I, and guidance on safe refuelling practices is contained in the Airport Services Manual (Doc 9137), Parts 1 and 8.*

Note 3.— *Additional precautions are required when refuelling with fuels other than aviation kerosene or when refuelling results in a mixture of aviation kerosene with other aviation turbine fuels, or when an open line is used.*

3.4.3.9 Oxygen supply

3.4.3.9.1 A flight to be operated at flight altitudes at which the atmospheric pressure in personnel compartments will be less than 700 hPa shall not be commenced unless sufficient stored breathing oxygen is carried to supply:

- a) all crew members and 10% per cent of the passengers for any period in excess of 30 minutes that the pressure in compartments occupied by them will be between 700 hPa and 620 hPa; and
- b) the crew and passengers for any period that the atmospheric pressure in compartments occupied by them will be less than 620 hPa.

3.4.3.9.2 A flight to be operated with a pressurized aeroplane shall not be commenced unless a sufficient quantity of stored breathing oxygen is carried to supply all the crew members and passengers, as is appropriate to the circumstances of the flight being undertaken, in the event of loss of pressurization, for any period that the atmospheric pressure in any compartment occupied by them would be less than 700 hPa. In addition, when an aeroplane is operated at flight altitudes at which the atmospheric pressure is less than 376 hPa, or which, if operated at flight altitudes at which the atmospheric pressure is more than 376 hPa and cannot descend safely within four minutes to a flight altitude at which the atmospheric pressure is equal to 620 hPa, there shall be no less than a 10-minute supply for the occupants of the passenger compartment.

3.4.4 In-flight procedures

3.4.4.1 Instrument approaches

3.4.4.1.1 *In the aircraft operating manual recommended in 3.6.1.2 the operator should include operating procedures for conducting instrument approaches.*

3.4.4.2 Use of oxygen

3.4.4.2.1 All flight crew members, when engaged in performing duties essential to the safe operation of an aeroplane in flight, shall use breathing oxygen continuously whenever the circumstances prevail for which its supply has been required in 3.4.3.9.1 or 3.4.3.9.2.

3.4.4.2.2 All flight crew members of pressurized aeroplanes operating above an altitude where the atmospheric pressure is less than 376 hPa shall have available at the flight duty station a quick-donning type of oxygen mask which will readily supply oxygen upon demand.

3.4.4.3 Aeroplane operating procedures for noise abatement

3.4.4.3.1 Aeroplane operating procedures for noise abatement should comply with the provisions of PANS-OPS (Doc 8168), Volume I.

3.4.4.3.2 Noise abatement procedures specified by the operator for any one aeroplane type should be the same for all aerodromes.

Note.— *A single procedure may not satisfy the requirements at some aerodromes.*

3.4.4.4 Aeroplane operating procedures for rates of climb and descent

Unless otherwise specified in an air traffic control instruction, to avoid unnecessary airborne collision avoidance system (ACAS II) resolution advisories in aircraft at or approaching adjacent altitudes or flight levels, pilots should consider using appropriate procedures to ensure that a rate of climb or descent of less than 8 m/s or 1500 ft/min (depending on the instrumentation available) is achieved throughout the last 300 m (1000 ft) of climb or descent to the assigned altitude or flight level, when made aware of another aircraft at or approaching an adjacent altitude or flight level.

Note.— *Material concerning the development of these procedures is contained in PANS- OPS (Doc 8168), Volume I, Part III, Section 3, Chapter 3.*

3.4.4.5 Aeroplane operating procedures for landing performance

An approach to land shall not be continued below 300 m (1000 ft) above aerodrome elevation unless the pilot-in-command is satisfied that, with the runway surface condition information available, the aeroplane performance information indicates that a safe landing can be made.

Note 1.— The procedures for using runway surface condition information on board aircraft are contained in the PANS- Aerodromes (Doc 9981) and in the performance section of the aeroplane flight manual; for aeroplanes certificated in accordance with ANO 8 (ANO AW Part 21), Part IIIB, in the Aeroplane Performance Manual (Doc 10064).

Note 2.— Guidance on development of aeroplane performance information for aeroplanes certificated in accordance with ANO 8 (ANO AW Part 21), Part IIIB is contained in the Aeroplane Performance Manual (Doc 10064).

3.4.5 Duties of pilot-in-command

3.4.5.1 The pilot-in-command shall ensure that the checklists specified in 3.4.2.5 are complied with in detail.

3.4.5.2 The pilot-in-command shall be responsible for notifying the nearest appropriate authority by the quickest available means of any accident involving the aeroplane, resulting in serious injury or death of any person or substantial damage to the aeroplane or property. In the event that the pilot-in-command is incapacitated the operator shall take the forgoing action.

Note.—A definition of the term “serious injury” is contained in Aircraft Accident Investigation Order (AAIO).

3.4.5.3 The pilot-in-command shall be responsible for reporting all known or suspected defects in the aeroplane, to the operator, at the termination of the flight.

3.4.5.4 The pilot-in-command shall be responsible for the journey log book or the general declaration containing the information listed in 2.8.2.

Note.—By virtue of Resolution A10-36 of the Tenth Session of the Assembly (Caracas, June–July 1956) “the General Declaration, [described in ANO 9] when prepared so as to contain all the information required by Article 34 [of the Convention on International Civil Aviation] with respect to the journey log book, may be considered by Contracting States to be an acceptable form of journey log book”.

3.4.6 Cabin baggage (take-off and landing)

The operator shall specify procedures to ensure that all baggage carried onto an aeroplane and taken into the passenger cabin is adequately and securely stowed.

CHAPTER 3.5 AEROPLANE PERFORMANCE OPERATING LIMITATIONS**3.5.1 General**

For aeroplanes for which Parts IIIA and IIIB of Annex 8 are not applicable because of the exemption provided for in Article 41 of the Convention, the State of Registry should ensure that the level of performance specified in 3.5.2 should be met as far as practicable.

3.5.2 Applicable to aeroplanes certificated in accordance with Parts IIIA and IIIB of ANO 8 (ANO AW Part 21) .

3.5.2.1 The provisions contained in 3.5.2.2 to 3.5.2.9 inclusive are applicable to the aeroplanes to which Parts IIIA and IIIB of ANO 8 (ANO AW Part 21) are applicable.

3.5.2.2 An aeroplane shall be operated in compliance with the terms of its certificate of airworthiness and within the approved operating limitations contained in its flight manual.

3.5.2.3 CAAB shall take such precautions as are reasonably possible to ensure that the general level of safety contemplated by these provisions is maintained under all expected operating conditions, including those not covered specifically by the provisions of this chapter.

3.5.2.4 A flight shall not be commenced unless the performance information provided in the flight manual indicates that the Provisions of 3.5.2.5 to 3.5.2.9 can be complied with for the flight to be undertaken.

3.5.2.5 In applying the provisions of this chapter, account shall be taken of all factors that significantly affect the performance of the aeroplane (such as: mass, operating procedures, the pressure altitude appropriate to the elevation of the aerodrome, runway slope, the ambient temperature, wind, and surface conditions of the runway at the expected time of use, i.e. presence of slush, water and/or ice, for landplanes, water surface condition for seaplanes). Such factors shall be taken into account directly as operational parameters or indirectly by means of allowances or margins, which may be provided in the scheduling of performance data or in the comprehensive and detailed code of performance in accordance with which the aeroplane is being operated.

Note.—Guidelines for using runway surface condition information on board aircraft in accordance with 2.2.4.4 are contained in the PANS-Aerodromes (Doc 9981) and in the Aeroplane Performance Manual (Doc 10064).

3.5.2.6 Mass limitations

- a) The mass of the aeroplane at the start of take-off shall not exceed the mass at which 3.5.2.7 is complied with, or the mass at which 3.5.2.8 and 3.5.2.9 are complied with, allowing for expected reductions in mass as the flight proceeds, and for such fuel jettisoning as is envisaged in applying 3.5.2.8 and 3.5.2.9 and, in respect of alternate aerodromes, 3.5.2.6 c) and 3.5.2.9.
- b) In no case shall the mass at the start of take-off exceed the maximum take-off mass specified in the flight manual for the pressure altitude appropriate to the elevation of the aerodrome, and if used as a parameter to determine the maximum take-off mass, any other local atmospheric condition.
- c) In no case shall the estimated mass for the expected time of landing at the aerodrome of intended landing and at any destination alternate aerodrome, exceed the maximum landing mass specified in the flight manual for the pressure altitude appropriate to the elevation of those aerodromes, and if used as a parameter to determine the maximum landing mass, any other local atmospheric condition.
- d) In no case shall the mass at the start of take-off, or at the expected time of landing at the aerodrome of intended landing and at any destination alternate aerodrome, exceed the relevant maximum masses at which compliance has been demonstrated with the applicable noise certification Standards in ANO 16, Volume I, unless otherwise authorized in exceptional circumstances for a certain aerodrome or a runway where there is no noise disturbance problem, by the competent authority of the State in which the aerodrome is situated.

3.5.2.7 Take-off. The aeroplane shall be able, in the event of a critical engine failing at any point in the take-off, either to discontinue the take-off and stop within either the accelerate- stop distance available or the runway available, or to continue the take-off and clear all obstacles along the flight path by an adequate margin until the aeroplane is in a position to comply with 3.5.2.8.

Note.—“An adequate margin” referred to in this provision is illustrated by the appropriate examples included in the Aeroplane Performance Manual (Doc 10064).

3.5.2.7.1 In determining the length of the runway available, account shall be taken of the loss, if any, of runway length due to alignment of the aeroplane prior to take-off.

3.5.2.8 **En route** — *one engine inoperative*. The aeroplane shall be able, in the event of the critical engine becoming inoperative at any point along the route or planned diversions therefrom, to continue the flight to an aerodrome at which the Provision of 3.5.2.9 can be met, without flying below the minimum obstacle clearance altitude at any point.

3.5.2.9 **Landing**. The aeroplane shall, at the aerodrome of intended landing and at any alternate aerodrome, after clearing all obstacles in the approach path by a safe margin, be able to land, with assurance that it can come to a stop or, for a seaplane, to a satisfactorily low speed, within the landing distance available. Allowance shall be made for expected variations in the approach and landing techniques, if such allowance has not been made in the scheduling of performance data.

Note.—*Guidance on appropriate margins for the “at time of landing assessment” are contained in the Aeroplane Performance Manual (Doc 10064).*

CHAPTER 3.6 AEROPLANE INSTRUMENTS, EQUIPMENT AND FLIGHT DOCUMENTS

Note.— Specifications for the provision of aeroplane communication and navigation equipment are contained in Chapter 3.7.

3.6.1 General

3.6.1.1 Where a master minimum equipment list (MMEL) is established for the aircraft type, the operator shall include in the operations manual a minimum equipment list (MEL) approved by the CAAB of the aeroplane which will enable the pilot-in-command to determine whether a flight may be commenced or continued from any intermediate stop should any instrument, equipment or systems become inoperative.

Note.— Attachment 3.B contains guidance on the minimum equipment list.

3.6.1.2 The operator should provide operations staff and flight crew with an aircraft operating manual, for each aircraft type operated, containing the normal, abnormal and emergency procedures relating to the operation of the aircraft. The manual shall be consistent with the aircraft flight manual and checklists to be used. The design of the manual shall observe Human Factors principles.

Note.— Guidance material on the application of Human Factors principles can be found in the Human Factors Training Manual (Doc 9683).

3.6.2 Aeroplanes on all flights

3.6.2.1 In addition to the requirements contained in 2.4.2.2, an aeroplane shall be equipped with:

- a) accessible and adequate medical supplies appropriate to the number of passengers the aeroplane is authorized to carry;
- b) *Medical supplies should comprise one or more first-aid kits.*

Note.— Guidance on the types, number, location and contents of the medical supplies is given in Attachment A to ANO 6, Part I.

- c) a safety harness for each flight crew seat. The safety harness for each pilot seat shall incorporate a device which will automatically restrain the occupant's torso in the event of rapid deceleration;

- d) *The safety harness for each pilot seat should incorporate a device to prevent a suddenly incapacitated pilot from interfering with the flight controls.*

Note.— Safety harness includes shoulder straps and a seat belt which may be used independently.

- e) means of ensuring that the following information and instructions are conveyed to passengers:
- 1) when seat belts are to be fastened;
 - 2) when and how oxygen equipment is to be used if the carriage of oxygen is required;
 - 3) restrictions on smoking;
 - 4) location and use of life jackets or equivalent individual flotation devices where their carriage is required;
 - 5) location of emergency equipment; and
 - 6) location and method of opening emergency exits.

3.6.2.2 An aeroplane shall carry:

- a) the operations manual prescribed in 3.4.2.2, or those parts of it that pertain to flight operations;
- b) the flight manual for the aeroplane, or other documents containing performance data required for the application of Chapter 3.5 and any other information necessary for the operation of the aeroplane within the terms of its certificate of airworthiness, unless these data are available in the operations manual; and
- c) the checklists to which 3.4.2.5 refers.

3.6.3 Flight recorders

3.6.3.1 Flight data recorders

3.6.3.1.1 Applicability

3.6.3.1.1.1 All aeroplanes of a maximum certificated take-off mass of over 5700 kgs for which the individual certificate of airworthiness is first issued on or after 1 January 2005 shall be equipped with an FDR which shall record at least 78 parameters listed in Table A2.3-1 of Appendix 2.3.

3.6.3.1.1.2 All aeroplanes of a maximum certificated take-off mass of over 27000 kgs for which the individual certificate of airworthiness is first issued on or after 1 January 1989 shall be equipped with an FDR which shall record at least the first 32 parameters listed in Table A2.3-1 of Appendix 2.3.

3.6.3.1.1.3 *All aeroplanes of a maximum certificated take-off mass of over 5700 kg, up to and including 27000 kg, for which the individual certificate of airworthiness is first issued on or after 1 January 1989, should be equipped with an FDR which should record at least the first 16 parameters listed in Table A2.3-1 of Appendix 2.3.*

3.6.3.2 Cockpit voice recorders

3.6.3.2.1 Applicability

3.6.3.2.1.1 All turbine-engined aeroplanes of a maximum certificated take-off mass of over 5700 kg for which the application for type certification is submitted to a Contracting State on or after 1 January 2016 and required to be operated by more than one pilot shall be equipped with a CVR.

3.6.3.2.1.2 All aeroplanes of a maximum certificated take-off mass of over 27000 kg for which the individual certificate of airworthiness is first issued on or after 1 January 1987 shall be equipped with a CVR.

3.6.3.2.1.3 *All aeroplanes of a maximum certificated take-off mass of over 5700 kg, up to and including 27000 kg, for which the individual certificate of airworthiness is first issued on or after 1 January 1987, should be equipped with a CVR.*

3.6.3.2.2 Duration

3.6.3.2.2.1 All aeroplanes of a maximum certificated take-off mass of over 27000 kg for which the individual certificate of airworthiness is first issued on or after 1 January 2022 shall be equipped with a CVR capable of retaining the information recorded during at least the last 25 hours of its operation.

3.6.3.3 Combination recorders

All aeroplanes of a maximum certificated take-off mass over 5700 kg, required to be equipped with an FDR and a CVR, may alternatively be equipped with two combination recorders (FDR/CVR).

3.6.3.4 Aeroplanes on long-range over-water flights

3.6.3.4.1 The operator of an aeroplane operated on an extended flight over water shall determine the risks to survival of the occupants of the aeroplane in the event of a ditching. The operator shall take into account the operating environment and conditions such as, but not limited to, sea state and sea and air temperatures, the distance from land suitable for making an emergency landing, and the availability of search and rescue facilities. Based upon the assessment of these risks, the operator shall, in addition to the equipment required in 2.4.4.3, ensure that the aeroplane is appropriately equipped with:

- a) life-saving rafts in sufficient numbers to carry all persons on board, stowed so as to facilitate their ready use in emergency, provided with such lifesaving equipment, including means of sustaining life, as is appropriate to the flight to be undertaken; and
- b) equipment for making the distress signals described in ANO 2.

3.6.3.4.2 Each life jacket and equivalent individual flotation device, when carried in accordance with 2.4.4.3, shall be equipped with a means of electric illumination for the purpose of facilitating the location of persons, except where the requirement of 2.4.4.3.1 is met by the provision of individual flotation devices other than life jackets.

3.6.3.5 Aeroplanes for which the individual certificate of airworthiness was first issued before 1 January 1990

3.6.3.5.1 Pressurized aeroplanes intended to be operated at flight altitudes at which the atmospheric pressure is less than 376 hPa shall be equipped with a device to provide positive warning to the flight crew of any dangerous loss of pressurization.

3.6.3.5.2 An aeroplane intended to be operated at flight altitudes at which the atmospheric pressure is less than 700 hPa in personnel compartments shall be equipped with oxygen storage and dispensing apparatus capable of storing and dispensing the oxygen supplies required in 3.4.3.9.1.

3.6.3.5.3 An aeroplane intended to be operated at flight altitudes at which the atmospheric pressure is less than 700 hPa but which is provided with means of maintaining pressures greater than 700 hPa in personnel compartments shall be provided with oxygen storage and dispensing apparatus capable of storing and dispensing the oxygen supplies required in 3.4.3.9.2.

3.6.4 Aeroplanes in icing conditions

Aeroplanes shall be equipped with suitable de-icing and/or anti-icing devices when operated in circumstances in which icing conditions are reported to exist or are expected to be encountered.

3.6.5 Aeroplanes operated in accordance with the instrument flight rules

3.6.5.1 In addition to the requirements contained in 2.4.7, aeroplanes when operated in accordance with the instrument flight rules, or when the aeroplane cannot be maintained in a desired attitude without reference to one or more flight instruments, shall be equipped with two independent altitude measuring and display systems.

3.6.5.2 Aeroplanes over 5700 kg — Emergency power supply for electrically operated attitude indicating instruments

3.6.5.2.1 Aeroplanes of a maximum certificated take-off mass of over 5700 kg newly introduced into service after 1 January 1975 shall be fitted with an emergency power supply, independent of the main electrical generating system, for the purpose of operating and illuminating, for a minimum period of 30 minutes, an attitude indicating instrument (artificial horizon), clearly visible to the pilot-in-command. The emergency power supply shall be automatically operative after the total failure of the main electrical generating system and clear indication shall be given on the instrument panel that the attitude indicator(s) is being operated by emergency power.

3.6.5.2.2 *Aircraft with advanced cockpit automation systems (glass cockpits) should have system redundancy that provides the flight crew with attitude, heading, airspeed and altitude indications in case of failure of the primary system or display.*

3.6.5.2.3 Instruments that are used by any one pilot shall be so arranged as to permit the pilot to see their indications readily from his or her station, with the minimum practicable deviation from the position and line of vision normally assumed when looking forward along the flight path.

3.6.6 Pressurized aeroplanes when carrying passengers—weather-detecting equipment

Pressurized aeroplanes when carrying passengers shall be equipped with operative weather- detecting equipment capable of detecting thunderstorms whenever such aeroplanes are being operated in areas where such conditions may be expected to exist along the route either at night or under instrument meteorological conditions.

3.6.7 Aeroplanes operated above 15 000 m (49 000 ft) — radiation indicator

Aeroplanes intended to be primarily operated above 15 000 m (49 000 ft) should carry equipment to measure and indicate continuously the dose rate of total cosmic radiation being received (i.e. the total of ionizing and neutron radiation of galactic and solar origin) and the cumulative dose on each flight. The display unit of the equipment shall be readily visible to a flight crew member.

Note.—*The equipment is calibrated on the basis of assumptions acceptable to the appropriate national authorities.*

3.6.8 Aeroplanes carrying passengers — cabin crew seats

3.6.8.1 Aeroplanes for which the individual certificate of airworthiness is first issued on or after 1 January 1981 Aeroplanes shall be equipped with a forward or rearward facing seat (within 15 degrees of the longitudinal axis of the aeroplane), fitted with a safety harness for the use of each cabin crew member required to satisfy the intent of 3.12.1 in respect of emergency evacuation.

3.6.8.2 Aeroplanes for which the individual certificate of airworthiness was first issued before 1 January 1981

3.6.8.2.1 Aeroplanes should be equipped with a forward or rearward facing seat (within 15 degrees of the longitudinal axis of the aeroplane), fitted with a safety harness for the use of each cabin crew member required to satisfy the intent of 3.12.1 in respect of emergency evacuation.

Note.—Safety harness includes shoulder straps and a seat belt which may be used independently.

3.6.8.2.2 Cabin crew seats provided in accordance with 3.6.8.1 or 3.6.8.2.1 shall be located near floor level and other emergency exits as required by the CAAB for emergency evacuation.

3.6.9 Aeroplanes required to be equipped with an airborne collision avoidance system (ACAS)

3.6.9.1 All turbine-engined aeroplanes of a maximum certificated take-off mass in excess of 15000 kg, or authorized to carry more than 30 passengers, for which the individual airworthiness certificate is first issued after 24 November 2005, should be equipped with an airborne collision avoidance system (ACAS II).

3.6.9.2 All turbine-engined aeroplanes of a maximum certificated take-off mass in excess of 15000 kg, or authorized to carry more than 30 passengers, for which the individual airworthiness certificate is first issued after 1 January 2007, shall be equipped with an airborne collision avoidance system (ACAS II).

3.6.9.3 All turbine-engined aeroplanes of a maximum certificated take-off mass in excess of 5700 kg but not exceeding 15000 kg, or authorized to carry more than 19 passengers, for which the individual airworthiness certificate is first issued after 1 January 2008, should be equipped with an airborne collision avoidance system (ACAS II).

3.6.10 Aeroplanes required to be equipped with a pressure-altitude reporting transponder

Aeroplanes shall be equipped with a pressure-altitude reporting transponder which operates in accordance with the relevant provisions of ANO 10, Volume IV.

Note.—This provision is intended to improve the effectiveness of air traffic services as well as airborne collision avoidance systems.

3.6.11 Microphones

All flight crew members required to be on flight deck duty shall communicate through boom or throat microphones below the transition level/altitude.

CHAPTER 3.7 AEROPLANE COMMUNICATION, NAVIGATION AND SURVEILLANCE EQUIPMENT

3.7.1 Communication equipment

In addition to the requirements of 2.5.1.1 to 2.5.1.5, an aeroplane shall be provided with radio communication equipment capable of:

- a) conducting two-way communication for aerodrome control purposes;
- b) receiving meteorological information at any time during flight; and
- c) conducting two-way communication at any time during flight with at least one aeronautical station and with such other aeronautical stations and on such frequencies as may be prescribed by the appropriate authority.

Note.—*The requirements of 3.7.1 are considered fulfilled if the ability to conduct the communications specified therein is established during radio propagation conditions which are normal for the route.*

3.7.2 Installation

The equipment installation shall be such that the failure of any single unit required for communications, navigation or surveillance purposes or any combination thereof will not result in the failure of another unit required for communications, navigation or surveillance purposes.

3.7.3 Electronic navigation data management

3.7.3.1 The operator of an aeroplane shall not employ electronic navigation data products that have been processed for application in the air and on the ground unless the State of Registry has approved the operator's procedures for ensuring that the process applied and the products delivered have met acceptable standards of integrity and that the products are compatible with the intended function of the existing equipment. CAAB shall ensure that the operator continues to monitor both the process and products.

Note.— *Guidance relating to the processes that data suppliers may follow is contained in RTCA DO-200A/EUROCAE ED-76 and RTCA DO-201A/EUROCAE ED-77.*

3.7.3.2 The operator shall implement procedures that ensure the timely distribution and insertion of current and unaltered electronic navigation data to all necessary aeroplanes.

CHAPTER 3.8 AEROPLANE CONTINUING AIRWORTHINESS**3.8.1 Operator's continuing airworthiness responsibilities**

3.8.1.1 The operator shall comply with the requirements of 2.6.1.

3.8.1.2 *The operator shall ensure that all maintenance personnel receive initial and continuation training acceptable to the CAAB and appropriate to their assigned tasks and responsibilities. This shall include Human Factors and coordination with other maintenance personnel and flight crew. This training program shall be in accordance with ANO (AW) Part-M.*

Note.— *Guidance material on the application of Human Factors principles can be found in the Human Factors Training Manual (Doc 9683).*

3.8.2 Operator's maintenance control manual

The operator shall comply with applicable requirements of ANO (AW) Part-M.

3.8.3 Maintenance programme

3.8.3.1 The operator shall provide, for the use and guidance of maintenance and operational personnel concerned, a maintenance programme, approved by the CAAB in accordance with ANO (AW) Part-M. The design and application of the operator's maintenance programme shall observe Human Factors principles.

Note.— *Guidance material on the application of Human Factors principles can be found in the Human Factors Training Manual (Doc 9683).*

3.8.3.2 Copies of all amendments to the maintenance programme shall be furnished promptly to all organizations or persons to whom the maintenance programme has been issued.

3.8.4 Continuing airworthiness information

The operator of an aeroplane of a maximum certificated take-off mass in excess of 5700 kg shall, as prescribed by the CAAB, ensure that the information resulting from maintenance and operational experience with respect to continuing airworthiness, is transmitted in accordance with applicable requirements of ANO (AW) Part-M and Part-145.

3.8.5 Maintenance release

3.8.5.1 When maintenance is carried out by an approved maintenance organization, the maintenance release shall be issued by the approved maintenance organization in accordance with the provisions of ANO (AW) Part-M and Part-145.

3.8.5.2 When a maintenance is not carried out by an approved maintenance organization, the maintenance release shall be completed and signed by a person appropriately licensed in accordance with ANO 1 to certify that the maintenance work has been performed in accordance with the maintenance programme or other data and procedures acceptable to the CAAB.

3.8.5.3 When maintenance is not carried out by an approved maintenance organization, the maintenance release shall include the following:

- a) basic details of the maintenance performed;
- b) the date such maintenance was completed; and
- c) the identity of the person or persons signing the release.

CHAPTER 3.9 AEROPLANE FLIGHT CREW

3.9.1 Composition of the flight crew

3.9.1.1 Designation of pilot-in-command For each flight, the operator shall designate a pilot to act as pilot-in-command.

3.9.1.2 Flight engineer

When a separate flight engineer's station is incorporated in the design of an aeroplane, the flight crew shall include at least one flight engineer especially assigned to that station, unless the duties associated with that station can be satisfactorily performed by another flight crew member, holding a flight engineer licence, without interference with regular duties.

3.9.2 Flight crew member emergency duties

The operator shall, for each type of aeroplane, assign to all flight crew members the necessary functions they are to perform in an emergency or in a situation requiring emergency evacuation. Recurrent training in accomplishing these functions shall be contained in the operator's training programme and shall include instruction in the use of all emergency and life-saving equipment required to be carried, and drills in the emergency evacuation of the aeroplane.

3.9.3 Flight crew member training programmes

3.9.3.1 The operator shall establish and maintain a training programme that is designed to ensure that a person who receives training acquires and maintains the competency to perform assigned duties, including skills related to human performance.

3.9.3.2 Ground and flight training programmes shall be established, either through internal programmes or through a training services provider, and shall include or make reference to a syllabus for those training programmes in the company operations manual.

3.9.3.3 The training programme shall include training to competency for all equipment installed.

3.9.3.4 *Flight simulators should be used to the maximum extent practicable for initial and annual recurrent training.*

3.9.4 Qualifications

3.9.4.1 Flight crew member licensing

3.9.4.1.1 The operator shall:

- a) ensure that each flight crew member assigned to duty holds a valid licence issued by the CAAB, or if issued by another Contracting State, rendered valid by the CAAB;
- b) ensure that flight crew members are properly rated; and
- c) be satisfied that flight crew members are competent to carry out assigned duties.

3.9.4.1.2 The operator of an aeroplane equipped with an airborne collision avoidance system (ACAS II) shall ensure that each flight crew member has been appropriately trained to competency in the use of ACAS II equipment and the avoidance of collisions.

Note 1.— Procedures for the use of ACAS II equipment are specified in the Procedures for Air Navigation Services — Aircraft Operations (PANS-OPS, Doc 8168), Volume I — Flight Procedures. ACAS II Training Guidelines for Pilots are provided in PANS-OPS, Volume I, Attachment A to Part III, Section 3, Chapter 3.

Note 2.— Appropriate training, to the satisfaction of the CAAB, to competency in the use of ACAS II equipment and the avoidance of collisions may be evidenced, for example, by:

- a) *possession of a type rating for an aeroplane equipped with ACAS II, where the operation and use of ACAS II are included in the training syllabus for the type rating; or*
- b) *possession of a document issued by a training organization or person approved by the State to conduct training for pilots in the use of ACAS II, indicating that the holder has been trained in accordance with the guidelines referred to in Note 1; or*
- c) *a comprehensive pre-flight briefing by a pilot who has been trained in the use of ACAS II in accordance with the guidelines referred to in Note 1.*

3.9.4.2 Recent experience — pilot-in-command

The operator shall not assign a pilot to act as pilot-in-command of an aeroplane unless that pilot has made at least three take-offs and landings within the preceding 90 days on the same type of aeroplane or in a flight simulator approved for the purpose.

3.9.4.3 Recent experience — co-pilot

The operator shall not assign a co-pilot to operate at the flight controls of an aeroplane during take-off and landing unless that pilot has made at least three take-offs and landings within the preceding 90 days on the same type of aeroplane or in a flight simulator approved for the purpose.

3.9.4.4 Pilot proficiency checks

The operator shall ensure that piloting technique and the ability to execute emergency procedures is checked periodically in such a way as to demonstrate the pilot's competence. Where the operation may be conducted under the instrument flight rules, the operator shall ensure that the pilot's competence to comply with such rules is demonstrated to either a check pilot of the operator or a representative of the State issuing the pilot licence.

Note.— *The periodicity of the checks referred to in 3.9.4.4 is dependent upon the complexity of both the aeroplane and the operation.*

CHAPTER 3.10 FLIGHT OPERATIONS OFFICER/FLIGHT DISPATCHER

The operator should ensure that any person assigned as a flight operations officer/flight dispatcher is trained and maintains familiarization with all features of the operation which are pertinent to their duties, including knowledge and skills related to Human Factors.

CHAPTER 3.11 MANUALS, LOGS AND RECORDS

Note.— The following document is associated with this ANO but is not included in this chapter: Operational flight plan — see 3.4.3.3.

3.11.1 Operator's maintenance control manual .

The Operator shall comply with the applicable requirements of ANO (AW) Part-M.

3.11.2 Maintenance programme

3.11.2.1 A maintenance programme for each aeroplane as required by 3.8.3 shall contain the following information:

- a) maintenance tasks and the intervals at which these are to be performed, taking into account the anticipated utilization of the aeroplane;
- b) when applicable, a continuing structural integrity programme;
- c) procedures for changing or deviating from a) and b) above as approved by the CAAB; and
- d) when applicable and approved by the CAAB, condition monitoring and reliability programme descriptions for aircraft systems, components and engines.

3.11.2.2 Maintenance tasks and intervals that have been specified as mandatory in approval of the type design, or approved changes to the maintenance programme, shall be identified as such.

3.11.2.3 The maintenance programme should be based on maintenance programme information made available by the State of Design or by the organization responsible for the type design, and any additional applicable experience.

3.11.3 Flight recorder records

The owner of the aeroplane, or in the case where it is leased, the lessee, shall ensure, to the extent possible, in the event the aeroplane becomes involved in an accident or incident, the preservation of all related flight recorder records and, if necessary, the associated flight recorders, and their retention in safe custody pending their disposition as determined in accordance with Aircraft Accident Investigation Order (AAIO).

CHAPTER 3.12 CABIN CREW**3.12.1 Assignment of emergency duties**

The requirement for cabin crew for each type of aeroplane shall be determined by the operator, based on seating capacity or the number of passengers carried, in order to effect a safe and expeditious evacuation of the aeroplane, and the necessary functions to be performed in an emergency or a situation requiring emergency evacuation. The operator shall assign these functions for each type of aeroplane.

3.12.2 Cabin crew at emergency evacuation stations

The Operator shall deploy cabin crew as per provision 3.12.1 on each flight. Each cabin crew member assigned to emergency evacuation duties shall occupy a seat provided in accordance with 3.6.8 during take-off and landing and whenever the pilot-in-command so directs.

3.12.3 Protection of cabin crew during flight

Each cabin crew member shall be seated with seat belt or, when provided, safety harness fastened during take-off and landing and whenever the pilot-in-command so directs.

3.12.4 Training

3.12.4.1 The operator shall ensure that a training programme is completed by all persons before being assigned as a cabin crew member.

3.12.4.2 The operator should establish and maintain a cabin crew training programme that is designed to ensure that persons who receive training acquire the competency to perform their assigned duties and includes or makes reference to a syllabus for the training programme in the company operations manual. The training programme may include Human Factors training.

Note.— Guidance material on the application of Human Factors principles can be found in the Cabin Crew Safety Training Manual (Doc 10002).

CHAPTER 3.13 SECURITY

3.13.1 Security programme

CAAB should ensure that each entity conducting general aviation operations, including corporate operator aviation operations, using aircraft with a maximum take-off mass greater than 5700 kg, establishes, implements and maintains a written operator security programme that meets the requirements of the national civil aviation security programme of Bangladesh.

Note.— *Accepted industry codes of practice may be used as the basis for the development of a written operator security programme.*

ATTACHMENT 3.A COMPANY OPERATIONS MANUAL*Supplementary to 3.4.2.2*

The following is the suggested content of a company operations manual. It may be issued in separate parts corresponding to specific aspects of an operation. It should include the instructions and information necessary to enable the personnel concerned to perform their duties safely and shall contain at least the following information:

- a) table of contents;
 - b) amendment control page and list of effective pages, unless the entire document is reissued with each amendment and the document has an effective date on it;
 - c) duties, responsibilities and succession of management and operating personnel;
 - d) operator safety management system;
 - e) operational control system;
 - f) MEL procedures (where applicable);
 - g) normal flight operations;
 - h) standard operating procedures (SOPs);
 - i) weather limitations;
 - j) flight and duty time limitations;
 - k) emergency operations;
 - l) accident/incident considerations;
 - m) personnel qualifications and training;
 - n) record keeping;
 - o) a description of the maintenance control system;
 - p) security procedures (where applicable);
 - q) performance operating limitations;
 - r) use/protection of FDR/CVR records (where applicable);
 - s) handling of dangerous goods; and
 - t) use of automatic landing systems, a HUD or equivalent displays and EVS, SVS or CVS equipment as applicable.
-

ATTACHMENT 3.B MINIMUM EQUIPMENT LIST (MEL)*Supplementary to 3.6.1.1*

1. If deviations from the requirements of CAAB in the certification of aircraft were not permitted, an aircraft could not be flown unless all systems and equipment were operable. Experience has proved that some unserviceability can be accepted in the short term when the remaining operative systems and equipment provide for continued safe operations.
2. CAAB should indicate through approval of a minimum equipment list those systems and items of equipment that may be inoperative for certain flight conditions with the intent that no flight can be conducted with inoperative systems and equipment other than those specified.
3. A minimum equipment list, approved by the CAAB, is therefore necessary for each aircraft, based on the master minimum equipment list established for the aircraft type by the organization responsible for the type design in conjunction with the State of Design.
4. CAAB shall require the operator to prepare a minimum equipment list designed to allow the operation of an aircraft with certain systems or equipment inoperative provided an acceptable level of safety is maintained.
5. The minimum equipment list is not intended to provide for operation of the aircraft for an indefinite period with inoperative systems or equipment. The basic purpose of the minimum equipment list is to permit the safe operation of an aircraft with inoperative systems or equipment within the framework of a controlled and sound programme of repairs and parts replacement.
6. Operators are to ensure that no flight is commenced with multiple minimum equipment list items inoperative without determining that any interrelationship between inoperative systems or components will not result in an unacceptable degradation in the level of safety and/or undue increase in the flight crew workload.
7. The exposure to additional failures during continued operation with inoperative systems or equipment should also be considered in determining that an acceptable level of safety is being maintained. The minimum equipment list may not deviate from requirements of the flight manual limitations section, emergency procedures or other airworthiness requirements of the CAAB or of the CAAB unless the appropriate airworthiness authority or the flight manual provides otherwise.

8. Systems or equipment accepted as inoperative for a flight should be placarded where appropriate and all such items should be noted in the aircraft technical log to inform the flight crew and maintenance personnel of the inoperative system or equipment.
 9. For a particular system or item of equipment to be accepted as inoperative, it may be necessary to establish a maintenance procedure, for completion prior to flight, to deactivate or isolate the system or equipment. It may similarly be necessary to prepare an appropriate flight crew operating procedure.
 10. The responsibilities of the pilot-in-command in accepting an aeroplane for operation with deficiencies in accordance with a minimum equipment list are specified in 2.2.3.1.
-

ATTACHMENT 3.C GUIDE TO CURRENT FLIGHT RECORDER PROVISIONS

Supplementary to Section 2, Chapter 2.4, 2.4.16 and Section 3, Chapter 3.6, 3.6.3

1. INTRODUCTION

Since 1973, and the inclusion in ANO 6 of SARPs for the carriage of flight recorders, new and revised requirements were introduced concerning flight recorders. These amendments include an update of the provisions pertaining to flight recorders, recording of digital communications, FDR requirements for new aircraft, revised parameter listings, and two-hour duration CVRs. Through the years, the applicability date and the carriage of flight recorders to be installed, as defined by the SARPs, were complex.

The tables below summarize the current flight recorders carriage requirements.

Table 3.C-1. SARPs for the recording of flight parameters

Date	Maximum certificated take-off mass (MCTOM)			
	Over 27000 kg		Over 5700 kg	
	All aeroplanes new type certificate	All aeroplanes first certificate of airworthiness	All aeroplanes new type certificate	All aeroplanes first certificate of airworthiness
1989 <input type="checkbox"/>		3.6.3.1.1.2		3.6.3.1.1.3
2005 <input type="checkbox"/>		3.6.3.1.1.1		3.6.3.1.1.1
2016 <input type="checkbox"/>		Table A2.3-1 (Some parameters are sampled at an increased frequency)		
2023 <input type="checkbox"/>	2.4.16.1.1.2	2.4.16.1.1.3	2.4.16.1.1.2	2.4.16.1.1.3

Table 3.C-2. CVR/CARS installation SARPs

Date	Maximum certificated take-off mass (MCTOM)		
	Over 27 000 kg	Over 5 700 kg	
	All aeroplanes first certificate of airworthiness	All aeroplanes first certificate of airworthiness	All turbine-engined aeroplanes operated by more than one pilot new type certificate
1987 <input type="checkbox"/>	3.6.3.2.1.2	3.6.3.2.1.3	
2016 <input type="checkbox"/>			3.6.3.2.1.1
2021 <input type="checkbox"/>	3.6.3.2.2.1		

Table 3.C-3. Combination recorder installation SARPs

Maximum certificated take-off mass (MCTOM)
Over 5 700 kg
All aeroplanes requiring an FDR and a CVR
3.6.3.3

Table 3.C-4. Data link communications (DLC) recording installation clarification

Rows	Date individual certificate of airworthiness was first issued	Date aircraft type certificate issued or modification for DLC equipment first approved	Date of activation for use of DLC equipment	DLC recording required	SARPs reference
1	On or after 1 January 2016	On or after 1 January 2016	On or after 1 January 2016	Yes	6.3.3.1.1
2	On or after 1 January 2016	Before 1 January 2016	On or after 1 January 2016	Yes	6.3.3.1.1
3	Before 1 January 2016	On or after 1 January 2016	On or after 1 January 2016	Yes	6.3.3.1.2
4	Before 1 January 2016	Before 1 January 2016	Before 1 January 2016	No	6.3.3.1.2
5	Before 1 January 2016	Before 1 January 2016	On or after 1 January 2016	No ¹	6.3.3.1.2 6.3.3.1.3

¹ Not required but recommended.

2. TABLE HEADINGS

2.1 *Date individual certificate of airworthiness was first issued* is self-explanatory.

2.2 *Date aircraft type certificate issued or modification for DLC equipment first approved* is the date that allows the installation of DLC equipment on the aircraft and refers to the airworthiness approval of the installation of aircraft components such as the structural and wiring provisions with which the DLC equipment needs to be compliant. These airworthiness approvals are usually in a form of a type certificate, a supplemental type certificate or an amended type certificate.

2.2.1 It is not uncommon for original customers of an aircraft that have airworthiness approvals related to DLC capability, to choose not to install the DLC equipment or choose not to have it activated even if the aircraft is prepared for it.

2.3 *Date of activation for use of DLC equipment* refers to the date that a DLC application referred to in 5.1.2 of Appendix 2.3 was first activated for use.

2.3.1 Datalink communication (DLC) equipment as used in these provisions, refer to physical unit(s) (e.g. box(es)) that was approved to a minimum performance the standard issued by a certification authority (e.g. TSO or ETSO).

2.3.2 The activation of DLC functions refer to approved software activation of DLC functions or software updates.

2.4 *DLC recording required* refers to the requirement to record DLC messages accordance with provisions 2.4.16.3.1.1, 2.4.16.3.1.2 and 2.4.16.3.1.3. in

3. GENERAL

3.1 It is the date on which the CVR capabilities of the aircraft were approved that determines the DLC recording requirement. The date in which the DLC equipment was approved to a minimum performance standard is not relevant for CVR recording requirement purposes.

3.2 For the DLC equipment to be compliant with an airworthiness approval, it needs to be able to use, without modification, the installed aircraft components that are necessary to provide the DLC function such as the:

- a) datalink router (e.g. hosted in the communications management unit);
- b) radios (e.g. VHF, HF datalink, SATCOM) and related antennas.

3.3 Approved software updates to installed equipment or software activation of functions normally do not alter the DLC equipment compliance with the rest of the aircraft systems.

4. EXAMPLES

4.1 For rows 1 and 2:

The recording requirement is driven by Standard 2.4.16.3.1.1 which is based on when the individual certificate of airworthiness was first issued. Any subsequent airworthiness modifications related to DLC capability do not exempt the aircraft from the requirement to record DLC messages.

4.2 For rows 3 to 5 — General:

The recording requirement is driven by Standard 2.4.16.3.1.2 and is based on whether or not the aircraft has an airworthiness approval for DLC capabilities and the date of its issue.

Since there was no requirement to record DLC messages prior to 1 January 2016, airworthiness approvals related to DLC capability issued before that date did not necessarily include this function.

4.3 For row 3:

The recording requirement applies regardless of when the certificate of airworthiness was issued, because an airworthiness approval related to DLC capability was issued on or after 1 January 2016. The date of installation of the equipment would typically be after the airworthiness approval.

4.4 For row 4:

The recording requirement does not apply because the aircraft's certificate of airworthiness and an airworthiness approval related to DLC capability was issued before 1 January 2016. The date of installation of DLC equipment is not a factor for DLC message recording requirements as long as the equipment is compliant with that airworthiness approval.

4.5 For row 5:

The recording requirement does not apply because the aircraft's certificate of airworthiness and an airworthiness approval related to DLC capability was issued before 1 January 2016. The date of installation of DLC equipment is not a factor for DLC message recording requirements as long as the equipment is compliant with that airworthiness approval.

Notwithstanding the above, if the installation of the DLC equipment is on or after 1 January 2016, DLC messages should be recorded in accordance with Recommendation 2.4.16.3.1.3.

ATTACHMENT 3.D AUTHORIZATIONS

An authorization entitles an operator, owner or pilot-in-command to undertake the authorized operations. Authorizations can take the form of specific approvals, approvals or acceptances.

1. SPECIFIC APPROVAL ACTIONS

- 1.1 The term “specific approval” indicates a formal action on the part of the State which results in an addition to the specific approval template.
- 1.2 The following provisions make explicit reference to the need for a specific approval:
 - a) operational credits for HUD, EVS, SVS, CVS, automatic landing systems [2.2.2.2.1.1];
 - b) low visibility operations [2.2.2.2.5, 2.2.2.2.6];
 - c) electronic flight bags [2.4.17.2.2];
 - d) AR navigation specifications for PBN operations [2.5.2.5]; and e) reduced vertical separation minima [2.5.2.7 (b)].
- 1.3 The specific approval template is provided in Appendix 2.4

2. APPROVAL ACTIONS

The term “approval” indicates a more formal action on the part of the State with respect to a certification matter than does the term “acceptance”. Some States require the Director of the Civil Aviation Authority (CAA) or a designated lower-level CAA official to issue a formal written instrument for every “approval” action taken. Other States allow a variety of documents to be issued as evidence of an approval. The approval document issued and the matter addressed by the approval will depend on the delegated authority of the official. In such States, authority to sign routine approvals is delegated to technical inspectors. More complex or significant approvals are normally issued by higher-level officials.

3. PROVISIONS THAT REQUIRE AN APPROVAL

The following provisions require or encourage approval by specified States. The approval of the CAAB is required in all of the certification actions listed below that are not preceded by an asterisk. Certification actions listed below that are preceded by one or more asterisks require approval by the CAAB (single asterisk or “*”), or by the State of Design (double asterisk or “**”). However, the CAAB should take the necessary steps to ensure that operators for which it is responsible comply with any applicable approvals issued by the State of Design, in addition to its own requirements.

Note.— Items that require a specific approval are not included here. Refer to 1.2 of this attachment for a list of these provisions.

- a) *Configuration deviation list (CDL) (Definitions);
- b) *Master minimum equipment list (MMEL) (Definitions);
- a) Aircraft-specific minimum equipment list (MEL) (Section 3, 3.6.1.1);
- b) Performance-based navigation operations (other than RNP-AR) (2.5.2.3);
- c) MNPS operations (2.5.2.6 (b));
- d) Procedures for electronic navigation data management (Section 3 3.7.3); and
- e) **Mandatory maintenance tasks and intervals (Section 3 3.11.2.2).